

PLAN

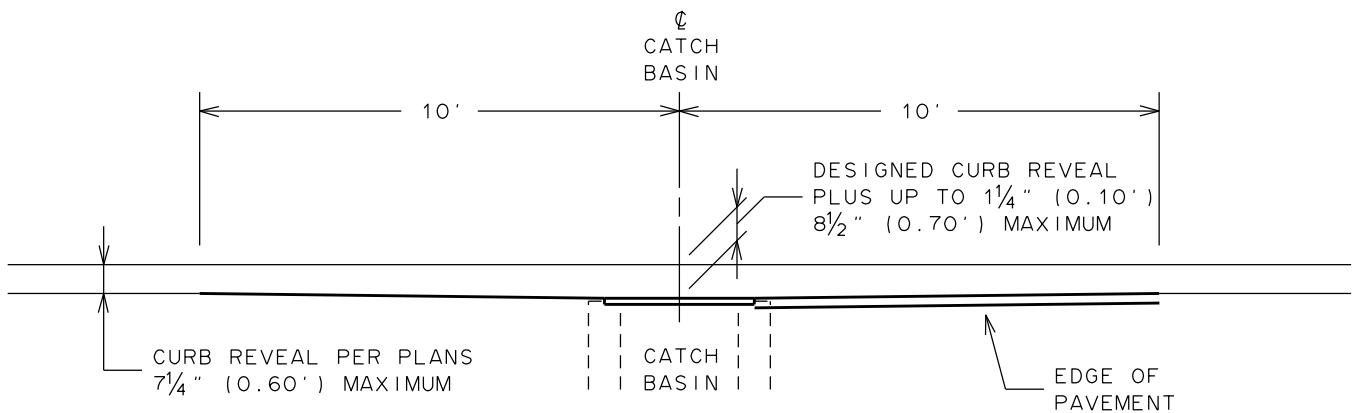

ELEVATION

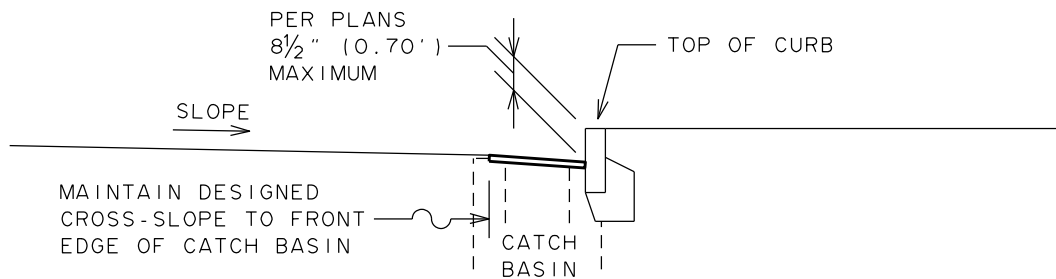

SECTION

NOTES:

1. DEPRESSED PAVING IS TO BE USED ONLY WHERE GRADES ARE LESS THAN 0.40%, AND AT LOW POINTS WHERE BOTH INCOMING GRADES ARE LESS THAN 0.50%.
2. BACKEDGE OF CATCH BASIN FRAME AND GRATE TO BE DEPRESSED AT CURB.
3. PAVEMENT IS TO BE FLUSH WITH CATCH BASIN.
4. TOP OF CURB IS TO REMAIN TRUE TO LINE AND GRADE. CURB IS NOT TO BE DEPRESSED.

CITY OF ROCHESTER		
DEPRESSED PAVING AT CATCH BASIN		
ISSUED	9-2-91	STANDARD DWG.NO.R400-3
REVISED	7-31-12	