



RULES AND REGULATIONS FOR WORK IN THE RIGHT-OF-WAY

*City of Rochester, New York
Department of Environmental Services
Bureau of Architecture and Engineering
Regulations authorized by Rochester City Code, Chapter 104*

*April 1, 2019
Updated: April 5, 2019*

These Rules and Regulations for Work in the Right-of-Way are adopted and maintained by the City Engineer and the Department of Environmental Services and shall be known as the “Rules and Regulations”.

For questions, please contact:

DESPermitOffice@CityofRochester.gov

Or visit:

www.cityofrochester.gov/streetpermits

or

www.cityofrochester.gov/rowpermits

Permit Office
Room 225B, City Hall
30 Church Street
Rochester, New York 14614

REVISION HISTORY

Date	Update	Notes
05/20/1997	Creation of Original Document	Titled “Standards for Work in the Public Right of Way”
04/01/2019	Document updates, including, but not limited to, the addition of telecommunications regulations	Renamed to “Rules and Regulations for Work in the Right-of-Way”. This version shall supersede all previous versions.

Table of Contents

1. Definitions And Abbreviations	6
1.1 Definitions	7
1.2 Abbreviations	7
1.3 Reference Documents	8
2. Introduction	9
2.1 General Information	9
2.2 Purpose	9
2.3 Legal Authority	9
2.4 Policy Goals	9
3. Examples of Work Requiring Permits	11
3.1 Permit Contents	11
4. Tips	12
4.1 Plan in Advance	12
4.2 Scale	12
4.3 Large Projects	12
5. Construction Requirements to Know Before You Begin	13
5.1 Abandoned Facilities	13
5.2 Americans with Disability Act	13
5.3 Backfill Materials	13
5.4 Concrete Sidewalks and Gutters	13
5.5 Curbs	13
5.6 Field Revisions	14
5.7 Pavement Cuts	14
5.8 Moratorium	14

5.9 Permanent Restoration	14
5.10 Restoration of Unique Surfaces	15
5.11 Sidewalks	15
6. Permit Process Overview	16
7. Permit Applications	17
7.1 Required Information and Submission	17
7.2 Site Plan Review	17
7.3 Permit Fees	18
7.4 Warranty	19
7.5 Security	19
7.6 Restoration Work Security	19
7.7 Insurance	20
7.8 Safe School Route Plan	20
7.9 Construction Schedule	20
7.10 Other Permits	21
8. Permittee Requirements	22
8.1 General Information	22
8.2 Public Notification	22
8.3 New York State Industrial Code, Rule 53	24
8.4 Labor and Materials	25
8.5 Use of Work Area	25
8.6 Maintenance and Protection of Traffic Plan	29
8.7 Traffic Control Board Approval	31
8.8 Punch Lists	32
8.9 As-Built Drawings	32
8.10 Guarantee, Testing and Failure	33

9. Telecommunications	34
9.1 Purpose	34
9.2 General Information	34
9.3 Permit Application Policy	34
9.4 Right-Of-Way Regulations	35
9.5 Permit Information Required	37
9.6 Information Required Post-Installation	39
9.7 Annual Inspection Certificate	39
9.8 Permit Expiration	40
9.9 Permit Non-Compliance	40
9.10 General Installation Requirements and Restrictions	40
9.11 Noise Restrictions	42
9.12 Radio Frequency Emissions Testing	42
9.13 Modifications to Existing Facilities and Equipment	42
9.14 Significant Gaps	42
9.15 New Technologies and Installation Methods	43
9.16 Training	43
9.17 General Design Standards for Facilities in the Right-of-Way	43
9.18 Maintenance of Facilities	45
9.19 GIS Maps	45
9.20 Construction and Standard of Care	47
9.21 Alternate Payment Procedures	47
10. Contact Information	49
Appendix A - City of Rochester Policies and Guidelines	50

1 DEFINITIONS AND ABBREVIATIONS

1.1 DEFINITIONS

Agency - The governmental unit (i.e. City, County, public authority) that may have facilities within the City's Right-of-Way.

Areaways - A recessed area below grade that is an extension of a building basement and may extend into the Right-of-Way. Areaways may be a chamber separated from the building by a wall or an extension of the building's basement without a wall; a sunken court or yard leading into a cellar for entrance of parcels, light or air.

City Code - The Municipal Code of the City of Rochester and all amendments thereto.

Day - Unless otherwise specified as a "business day," the term "day" shall be deemed a calendar day.

Drawings - The drawings and applicable detail sheets that show the location, detail, character, dimensions and elevations of work to be performed.

Excavation - Any movement or removal of earth, rock, pavement, Right-of-Way fixtures or other materials in or on the ground.

Excavator - Any person who conducts, undertakes, or carries out an Excavation.

Interference - Physically or electronically affecting the operation, views, signals or functions of City or third-party equipment.

New York State Industrial Code Rule 53 - New York State regulations (16 NYCRR 753) regarding the construction, excavation, and demolition operations at or near underground facilities to assure safety and prevent damage to public or private property.

Pavement - The paved portion of a street used for vehicular travel usually made of asphalt, concrete, brick, or other paving material.

Permit - A document and any attachments or amendments thereto from the Department of Environmental Services' Permit Office granting revocable permission to perform work under described conditions in the Right-of-Way.

Permit Applicant ("Applicant") - Any individual, firm, corporation or governmental unit or public authority that is seeking a Permit to perform work in the Right-of-Way.

Permit Conditions ("Conditions") - Term aggregating Standard Conditions and Supplementary Conditions of a Permit.

Permittee - Any individual, firm, corporation or governmental Agency that has been granted permission in the form of a Permit to perform work in the Right-of-Way according to the conditions set forth in the Permit documents.

Permit Office - City of Rochester, Department of Environmental Services, Permit Office located in Room 125B City Hall, 30 Church Street, Rochester, New York, 14614.

Right-of-Way - The area on, below or above a City-owned or controlled street, roadway, alley or sidewalk, including the curbs, gutters, catch basins and related facilities adjacent thereto.

Schedule - A coordinated work plan indicating start and end dates. Work that is divided into phases such as more complex or large scale Permit work, shall indicate start and end dates for each phase of the work.

Security – A financial instrument, including a letter of credit, certified check, cash, bond or other formal assurance used to guarantee that the Permit work will be properly performed and completed, that any Right-of-Way restoration work will be maintained as required by the City Code, these Rules and Regulations, the Permit and any agreements, and that all fees and compensation owed to the City are paid in full. Such security shall be in a form approved by the Director of Finance or the Corporation Counsel.

Sensitive Location – A location within a Preservation District, within 200 feet of a designated City Landmark or within 200 feet of a property listed or eligible for listing on the National Register of Historic Places District or a National Register of Historic Places site.

Stake Out - Surface markings placed to indicate the presence and location of buried facilities such as gas, water, sewer, electric, telephone, cable television, etc.

Standard Conditions - General requirements for work in the Right-of-Way.

Supplementary Conditions - Specific requirements modifying or in addition to the Standard Conditions of the Permit documents for a particular Permit.

Survey Monuments - Permanent markers set under the direction of a New York State Licensed Land Surveyor to denote theoretical positions. There are both horizontal and vertical Survey Monuments.

Traffic Control Board - The board authorized by City Code to establish and/or to modify traffic regulations in the City of Rochester. The City Engineer is chairperson of the Traffic Control Board.

Work Area - The section of the Right-of-Way as identified in the Permit documents where the Permittee has been granted permission to perform construction activities.

1.2 ABBREVIATIONS

CCD – Center City District

DES - Department of Environmental Services, Rochester, New York

DBH - In the United States and Canada, the diameter of standing trees is measured at breast height - 4.5 feet above ground

NYS DOT - New York State Department of Transportation

NYS DOT MUTCD - New York State Department of Transportation Manual of Uniform Traffic Control Devices

OSHA - Occupational Safety and Health Administration

1.3 REFERENCE DOCUMENTS

Before Beginning Work in the Right-of-Way:

1. Review your approved Permit documents;
2. Review *Rules and Regulations for Work in the Right-of-Way*, latest edition;
3. Review the *City of Rochester Standard Construction Documents – Specifications and Details*, located at: <http://www.cityofrochester.gov/constructiondocuments/>;
4. Review the *New York State Department of Transportation Standard Specifications (US Customary Units): Construction and Materials*, latest edition, available at: <https://www.dot.ny.gov/main/business-center/engineering/specifications>.

2 INTRODUCTION

2.1 GENERAL INFORMATION

The following Rules and Regulations established by the City Engineer, as authorized by section 104-32 of the City Code, govern the policies and standards required of all work performed in the Right-of-Way. The Right-of-Way includes all City streets, street Pavement, curbing, sidewalks, the area between the curb and the sidewalk, and in most residential areas it generally includes a zero to four (4) foot width of land between the sidewalk and the home.

The Right-of-Way can be identified by Survey Monuments that provide horizontal control. They are found in the sidewalk area at most street intersections or other critical points, like angle points and curvatures within the Right-of-Way line.

2.2 PURPOSE

These Rules and Regulations have been developed to:

1. Protect and preserve the Right-of-Way, one of the City's most valuable assets;
2. Protect the health and safety of drivers, pedestrians, citizens and visitors using the Right-of-Way;
3. Ensure that Permittees minimize disruptions to the public, businesses, and the City; and
4. Ensure that Permittees properly and sufficiently restore the Work Area once the work is complete.

2.3 LEGAL AUTHORITY

Work within the Right-of-Way is under the jurisdiction of the City Engineer and is primarily governed by Chapter 104 of the City Code ("Chapter 104"). The City Engineer has the authority to issue Permits, regulate certain Right-of-Way activities, and create these Rules and Regulations for work in the Right-of-Way.

2.4 POLICY GOALS

These Rules and Regulations are adopted to ensure the safe condition of the Right-of-Way and to protect all Right-of-Way users.

1. Safe procedures and outcomes: Failure to abide by these Rules and Regulations may lead to unsafe conditions, including but not limited to those that may lead to injury and loss of life; interference with gas and electric utilities, telephone, cable television, street lighting or other utilities; and property damage. These Rules and Regulations require that work in the Right-of-Way be done safely and properly by insured parties, and only after being issued a Permit by the City Engineer.

2. Minimal disruptions: Work in the Right-of-Way can be disruptive to pedestrians, businesses, and vehicle traffic. These Rules and Regulations ensure that work is completed with minimal disruption.
3. Appropriate work: These Rules and Regulations ensure that plans for work in the Right-of-Way are appropriate and accurately described in advance, and that restoration of the Work Area is completed at the Permittee's expense.

3 EXAMPLES OF WORK REQUIRING PERMITS

3.1 PERMIT CONTENTS

WORK AND ACTIVITIES OCCURRING WITHIN THE RIGHT-OF-WAY, INCLUDING BUT NOT LIMITED TO THE FOLLOWING, SHALL REQUIRE A PERMIT:

- **DRIVEWAY and CURB MODIFICATIONS:** Work including resurfacing, widening, creating, installing, replacing or closing an existing driveway or curbing.
- **ENCROACHMENTS:** Any encroachments, including signs, banners, awnings, public facilities, marquees, areaways, air conditioners, telecommunications equipment and facilities, etc.
- **EXCAVATION:** Installation, repair or replacement of equipment underground, including but not limited to water services, sewer laterals, underground utilities, and telecommunications equipment or facilities.
- **HEAVY EQUIPMENT:** Use of cranes, scaffolding, fork trucks, or other heavy equipment.
- **NEW STREETS:** Installation of new streets dedicated to the City upon completion.
- **OVERSIZED and OVERWEIGHT:** Use of oversized vehicles or overweight loads.
- **POLES:** Installation of new poles, replacement poles, or relocation of existing poles (utilities, street lighting, telecommunications, etc.).
- **REPAIR and REPLACEMENT:** Work involving Pavement, sidewalks, driveways, or streets.
- **SIDEWALK CAFES:** Placement of tables and seating.
- **STORAGE:** Storage of dumpsters, equipment, or other materials.
- **WATER:** Disconnection of water service or requests to use of hydrants during work (demolition, etc.).

THE FOLLOWING INFORMATION OR CONDITIONS MAY BE INCLUDED WITH AN APPROVED PERMIT:

1. Supplementary Conditions that modify the Standard Conditions applicable to Permit work;
2. Specifications of the work or project;
3. Drawings of the location, character, dimensions, and cross-sections of the work;
4. Approved Schedule for the work.

4 TIPS

4.1 PLAN IN ADVANCE

Applicants must give adequate time for review and approval by the Permit Office and any other involved agencies.

Tip: Call or email the Permit Office well in advance of any Scheduled work to obtain early guidance.

4.2 SCALE

The City's standard scale is one (1) inch = twenty (20) feet, unless otherwise specified. All plans submitted to the City for review should use this scale.

Tip: Submitting plans using this scale will likely expedite the application.

4.3 LARGE PROJECT COORDINATION

Large projects may require the coordination of many entities, including developers, engineers, owners, County or State agencies, and other stakeholders along with the City, and may require Site Plan Review or Traffic Control Board approval.

Tip: Schedule a pre-application conference to discuss the project's Permit requirements, scope, phasing, coordination, and fees in advance.

5 CONSTRUCTION REQUIREMENTS TO KNOW BEFORE BEGINNING:

5.1 ABANDONED FACILITIES

Any facilities in the Right-of-Way must be continuously maintained by the Permittee. If any facilities are abandoned, Permittee must notify the City and remove the facilities at their own cost. During the time between abandonment and removal, Permittee shall continue to provide records and Drawings of the abandoned facilities until Permittee removes the facilities from the Right-of-Way. Permittee shall remove or modify its abandoned facilities at the sole discretion of the City Engineer.

Any abandoned facilities that are not removed timely as required by the City Engineer may be removed or caused to be removed by the City and all related costs shall be billed to the Permittee or satisfied by drawing on the Permittee’s Security.

In the alternative, only if approved in writing by the City Engineer, Permittee may abandon the facilities in place and, at the City’s sole discretion, ownership to such abandoned facilities shall be deemed transferred to the City. If facilities remain abandoned in place, Permittee shall maintain continued stake out location information as required by Dig Safely New York.

5.2 AMERICANS WITH DISABILITIES ACT

The Permittee is required to ensure that all travelled ways are fully accessible for persons with disabilities in compliance with the Americans with Disabilities Act (ADA), any other applicable law, rules or regulations, and the Proposed Guidelines for Pedestrian Facilities in the Right-of-Way (PROWAG) during all phases of work.

5.3 BACKFILL MATERIALS

The following are unacceptable for use as backfill and sub-base course materials in the Right-of-Way: recycled materials, pulverized or recycled portland cement, concrete aggregate (RCA), brick, reclaimed asphalt Pavement (RAP), and Corian, unless specifically authorized in writing by the City Engineer. All materials shall comply with Section 8.4 Labor and Materials.

5.4 CONCRETE SIDEWALKS AND GUTTERS

Concrete sidewalks and gutters must not be covered with asphalt.

5.5 CURBS

Removal and resetting of existing curb shall be done in full pieces only with the limits for curb work to be extended out to the nearest joint. There shall be no partial saw-cutting of the existing curb to accommodate the work. Additional pieces of existing curb and underdrain pipe that are damaged during the work shall be fully removed and replaced with new materials of like characteristics at the Permittee’s cost.

5.6 FIELD REVISIONS

All field revisions require additional review and approvals by the Permit Office.

5.7 PAVEMENT CUTS

Pavement saw cuts shall be full depth, extending through the Pavement base course.

5.8 MORATORIUM

Once a street is constructed, reconstructed, or rehabilitated, and including but not limited to, chip seal and milling and resurfacing by the City, it shall not be open to Excavation for a period of three years with the exception of emergencies or where such a requirement is waived by the City Engineer for good cause. Failure to comply with this policy will not justify a waiver.

If the moratorium is waived for emergency or good cause, the Permittee will be responsible for the complete restoration, milling, and resurfacing the area as required by the City Engineer. This policy goes into effect on May 1, 2019.

5.9 PERMANENT RESTORATION

Unless otherwise determined by the City Engineer, permanent restoration is required for all work associated with the Permit. All locations require permanent restoration as follows:

1. Excavations which impact only half (1/2) of the street lane, curb/pavement edge to center line, will require complete mill and resurface of the impacted street width lane (curb/pavement edge to center line).
2. Excavations which traverse across the center line and impact both street width lanes will require complete, edge of pavement to edge of pavement, mill and resurface of the impacted street location.
3. Mill and resurface linear limits of the excavations shall extend ten (10) feet beyond the initial excavation restoration areas, in both directions.
4. Locations which include multiple excavations, within forty (40) feet of each other, shall require a special review by the Permit Office to determine the overall extent of the pavement restoration.
5. All excavations must include standard pavement base restoration in accordance with the City's standards and specifications, and must be performed prior to the mill and resurface restoration component. It is the responsibility of the Permittee to stay up-to-date with the *City of Rochester Standard Construction Documents – Specifications and Details*, located at:
<http://www.cityofrochester.gov/constructiondocuments/>

5.10 RESTORATION OF UNIQUE SURFACES

Any special or unique surfaces shall be restored in-kind. For example, brick or cobblestone surface streets require all Pavement cuts to be restored with like materials and special design sidewalks shall be restored in-kind. Permittees are required to salvage as much of the existing materials as possible for reuse in the restoration, and shall supply any new material with substantially similar characteristics as required for proper restoration.

5.11 SIDEWALKS

Replacement of existing sidewalk areas shall be the nearest control joint and in full flag segments only of the same materials and design. No saw-cutting or partial replacement of the existing sidewalk to accommodate the work within the Right-of-Way shall be permitted. Additional areas of the existing sidewalk that are damaged during the work shall be replaced.

6 PERMIT PROCESS OVERVIEW

1. Applicant completes a Permit application and submits plans, Drawings, the Schedule of work, the applicable Permit fee, and in the case of telecommunications facilities or equipment, a completed registration as required by section 106-5 of the Telecommunications Code;
2. Permit Office reviews the completed application and either approves, rejects, or requests modifications/revisions to the application;
3. If revisions are necessary, applicant resubmits the application;
4. Upon approval, the applicant must provide the Security and the required insurance documents (workers' compensation, disability, and liability);
5. Review and approval of submitted Security conducted by the Corporation Counsel or Director of Finance
6. Any changes to the Schedule or scope of the Permit must be submitted to the Permit Office in writing immediately for review and approval.
7. For all telecommunications equipment or facilities Permits, payment of all fees and compensation required by a Master License Agreement or other Right-of-Way agreement.

7 PERMIT APPLICATIONS

7.1 REQUIRED INFORMATION AND SUBMISSIONS

All Permit applicants shall submit the following before a Permit application will be processed:

1. Three copies of scaled Drawings (one inch = twenty feet) or plans as otherwise specified by the City that clearly indicate the proposed work to be done, which must include:
 - a. All Right-of-Way and property lines
 - b. Existing and proposed sidewalks
 - c. Existing and proposed curb lines
 - d. Existing and proposed driveways
 - e. Existing and proposed utilities, both overhead and underground
 - f. Existing and proposed features and facilities in the Right-of-Way
 - g. Street names, intersecting streets, and street widths
 - h. Survey Monuments (contact the City's Maps and Survey's Department)
 - i. Restoration details in accordance with the City of Rochester Standard Construction Document Specifications and Details.
2. Plan for maintenance and protection of traffic, including Traffic Control Board approval where required
3. Construction Schedule, including schedules for each major phase of work
4. Required Permits from other public agencies (e.g. County, NYSDOT, U.S. Army Corps of Engineers, etc.)
5. Any required maintenance agreements or existing or proposed easements
6. Any additional items as required or deemed necessary by the City Engineer

7.2 SITE PLAN REVIEW

Projects on private property that include or impact work in the Right-of-Way and require Site Plan approval pursuant to the Zoning Code, shall be reviewed and approved by the Manager of Zoning. For such projects, all of the above requirements for "Permit Applications" must be submitted along with three copies of Drawings or plans, as well as:

1. The proposed development frontage, plus a minimum distance of fifty (50) feet in each direction along both sides of the Right-of-Way. For new subdivisions and re-subdivisions, the plans must include a minimum distance of two hundred (200) feet in each direction along both sides of the Right-of-Way;
2. All property lines, owners' names, parcel numbers, and addresses of adjacent property owners;
3. Any existing and proposed easements regarding site access, new streets, and Right-of-Way changes;
4. All above-ground features, such as trees, poles, street lights, hydrants, manholes, raised medians, etc.;
5. A three-inch by three-inch (3" x 3") square space reserved near the title block for approval stamps;
6. When plans contain any features that are designed by a professional engineer, the full set of plans are to be stamped and approved by a N.Y.S. Licensed Professional Engineer;
7. Surface contours and elevations in half-foot (0.50') intervals, including the elevation of high and low spots;
8. Invert elevations and sizes of drainage facilities, such as sewer main and lateral pipes and manholes within two hundred (200) feet of the proposed work;
9. Drainage calculations of any improvements that impact drainage of storm water runoff; and
10. Ownership and maintenance of drainage easements.

7.3 PERMIT FEES

Permit fees are detailed in the City Engineer's Permit Fee Schedule available on the City's website and in the Permit Office. Please note that additional fees may apply, including but not limited to:

- Excavation work that may impact the accuracy of Rochester City Survey Monuments (RCS) will require an additional fee. These fees will be determined by the City's Maps and Surveys Office after reviewing the applicant's work plans, and will be based upon the number and location of the affected RCS Survey Monuments impacted.
- Full-time inspection services of a City employee may be required on projects requiring extensive and complex construction procedures. This expense will be the responsibility of the Permit Applicant.

- Any Permitted work that will require Official Map amendments.
- The cost of expert opinions as the City deems necessary (especially issues regarding bridges or infrastructure, telecommunications, complex engineering, etc.).
- Assessments and replacement costs for affected trees incurred by City Forestry.

7.4 WARRANTY

The Permittee shall warrant that any trench backfill, Pavement restoration, or other work performed by the Permittee or its employees, agents, and contractors in the Right-of-Way will be free from all defects due to faulty materials or quality of work for a period of two (2) years after the date the work was inspected and approved by the City. Upon failure of the pavement restoration within the two (2) year warranty period, the Permittee shall repair or remove and replace all such backfill, Pavement restoration, or other work, together with any other Pavement areas directly affected by that removal or replacement, without any expense to the City. If the Permittee fails to comply diligently with these provisions within ten (10) Days after being notified in writing (or in cases of emergency, within twenty-four hours), the City is authorized to proceed to have any backfill, Pavement restoration, or other defects remedied at the sole cost and expense of the Permittee, and Permittee is obligated to pay those costs and expenses within thirty (30) Days of receipt of the invoice. In the alternative, the City may draw upon the project Security to reimburse the City for all costs and expenses incurred to cure or repair the deteriorated or failed Pavement restoration. Such action by the City shall not relieve the Permittee of the warranty provided for in this section. The warranty requirement shall extend for an additional two (2) years from the date of any repair or replacement made necessary by this section.

7.5 SECURITY

Pursuant to Chapter 104, Permit Applicants shall provide Security, sufficient to ensure completion of Applicant's project, proper restoration of the Work Area, and payment of all associated costs and fees associated with the project. Such Security may include a letter of credit, a certified check, cash, a performance and payment bond, or other Security instrument in a form approved by the Director of Finance or the Corporation Counsel, and in an amount approved by the City Engineer for proper protection of the Right-of-Way. Such Security shall be unconditional and irrevocable and maintained for the life of the project and for such period of time after completion as is necessary for protection of the Right-of-Way, generally two (2) years as set forth below. If such time period is not specified by the City Code or a written agreement, it shall be defined by the City Engineer. The Security will not be released until final inspection of the work meets the City's approval or until the time period as described in this section or by agreement, expires.

7.6 RESTORATION WORK SECURITY

Pursuant to Chapter 104, Chapter 106, and the requirements of any master license agreement, Permit Applicants shall maintain Security to ensure that all restoration work in

the Right-of-Way will survive for a minimum of two (2) years, or such longer period as determined by the City Engineer. The project Security shall be maintained for the minimum two (2) year period after project completion but upon inspection and approval of the project and confirmation that all fees and payments have been made to the City, the Security amount may be reduced to the amount of twenty-five percent (25%) plus 15% administrative cost, 10% RPR inspection cost, and 10% contingency of the project costs as determined by the City Engineer. Any failed restoration work and subsequent repairs will restart the two (2) year Security requirement

7.7 INSURANCE

1. **WORKERS' COMPENSATION AND DISABILITY:** Permittee shall obtain and provide proof of coverage for Workers' Compensation and Disability Insurance (as required by law), which shall be maintained and in full force and effect until completion of the work. This shall cover all operations and work under the Permit, whether performed by the Permittee or any of its agents, employees, or subcontractors.
2. **GENERAL LIABILITY INSURANCE:** Permittee shall obtain and maintain comprehensive general liability insurance throughout the duration of the Permit work and in the case of encroachments, as defined in Chapter 104, so long as the encroachment remains in the Right-of-Way. The policy shall name the City as an additional insured. The comprehensive general liability policy shall furnish combined single limits for all damages arising during the policy period of not less than the applicable amounts set forth in Chapter 104, in a Master License Agreement, other Right-of-Way agreement, or as specified in the Permit.

7.8 SAFE SCHOOL ROUTE PLAN

If the proposed work will impact school pedestrian and school bus traffic, the Permittee must contact the City's Transportation Specialist to request a Safe School Route Plan. A copy of the Plan must be submitted to the Permit Office. The Safe School Route Plan must be maintained for the duration of the construction unless otherwise directed by the Permit Office representative.

7.9 CONSTRUCTION SCHEDULE

The Permit Applicant shall submit a Schedule indicating the proposed start and end dates of each major phase of the Permit work. Any requests to modify an approved Permit Schedule must be submitted in writing to the Permit Office for review and approval. The Permit Office shall be notified at least two business days before the start of construction.

Schedules shall be designed to provide time for permanent restoration of Pavement before the fall asphalt plant closings. Asphalt plants normally close in mid-November. If permanent restoration is not possible prior to the asphalt plant closings, then the Permittee is responsible for providing and maintaining temporary Pavement restoration over the winter season until permanent restoration is completed.

7.10 OTHER PERMITS

Permit Applicants are responsible for obtaining separate permits for the following work:

- **ROCHESTER BUREAU OF WATER PERMITS:**
 - Applicants for new water service Permits must initiate the application process at the Rochester Bureau of Water and complete the Permit at the City Permit Office.
 - Hydrant use Permits are required before using any hydrant as a source of water. The Permit requires the use of a water meter and backflow preventer. Upon payment of the permit fee and refundable deposit, the Bureau of Water will supply a hydrant wrench, water meter, meter setting, and backflow preventer. Hydrant use Permits can be obtained at the Water Maps and Records Office.
- **RAILROAD RIGHT-OF-WAY PERMITS:** A permit from the railroad company is required when the Work Area extends into a railroad's right-of-way. These permits require the applicant to obtain additional insurance. Permit Applicant is responsible for contacting the railroad at issue for further details.
- **PURE WATERS DISTRICT PERMIT:** When the work consists of a sanitary or storm service lateral connection, applicants must obtain a separate permit from the Pure Waters District's permit office.
- **NEW YORK STATE DEPARTMENT OF TRANSPORTATION:** When the Work Area extends into a State right-of-way, applicants must obtain a permit from the New York State Department of Transportation.
- **UNITED STATES ARMY CORP OF ENGINEERS:** When the Work Area extends into any navigable waterways or wetlands, applicants must obtain a permit from the United States Army Corp of Engineers.

8 PERMITTEE REQUIREMENTS

8.1 GENERAL INFORMATION

Permittees must ensure compliance with all local, State, and Federal laws, regulations, specifications, and ordinances, including these Rules and Regulations. A copy of the permit shall be available on-site whenever work is being performed.

All Work Areas in the Right-of-Way shall:

- Maintain and protect traffic in accordance with the *MUTCD* and *MUTCD Supplement*
- Be fully accessible to persons with disabilities in compliance with the Americans with Disabilities Act (ADA) and the Proposed Rights-of-Way Accessibility Guidelines (PROWAG) during all phases of the work

All work performed in the Right-of-Way shall:

- Keep disruption to a minimum
- Limit the duration of the project as much as possible
- Be restored in a quality manner and in compliance with section 5 of the Rules and Regulations
- Be controlled by the Permittee, who is responsible for all supervision of its employees and any subcontractors at all times, and who shall maintain control and order over the work activities and Work Area at all times.

8.2 PUBLIC NOTIFICATION

1. CONSTRUCTION START NOTIFICATION LETTERS

When directed in the Supplementary Conditions Sheet of the Permit Documents, a letter must be hand-delivered and mailed to all addresses within the Work Area, other designated areas, and to the Permit Office. The letter shall be received by all addresses at least two Days before commencing the work and must include the project limits, general scope of work, construction start and end dates, and name of contractor if other than the Permittee.

2. NOTICE OF LIMITED PROPERTY ACCESS OR DISRUPTION OF UTILITY SERVICES

When the Permit work will affect residents or business' access to their property or will disrupt utility services, written notices must be hand delivered by means of door hangers to each address, business, and/or residence, as well as to the Permit Office. The Work Area and Schedule must be included on the notice and all notices delivered at least five (5) business days in advance of commencing work.

3. EMERGENCY NOTIFICATION

In case of emergencies affecting the safety or protection of persons or property at or near the Work Area, the Permittee shall act promptly to prevent any actual or threatened damage, injury, or loss. The Permit Office shall be notified immediately of any damage to the Right-of-Way. Night and weekend emergency notification shall be directed to the Bureau of Water Dispatch Office.

A permit is required even when a street opening is necessary to address an emergency. The Street Right-of-Way Office should be notified as soon as possible, and a permit application must be submitted within (48) hours.

4. PROJECT SIGNS

When directed in the Supplementary Conditions Sheet of the Permit, project signs shall be placed at the limits of the Work Area. These signs shall be installed before the start of work in the Right-of-Way. The minimum dimensions of the sign shall be three feet high by four feet wide (3'H x 4'W) and shall include the following information:

- Permittee's name
- Permittee's telephone number
- Nature of the work
- Contractor's name

Lettering shall be a minimum of two and a half inches (2.5") high and contrast with the background color to be easily readable.

The bottom of the project signs shall be mounted a minimum of five feet (5') off the ground and be solidly constructed and securely mounted on their own posts or barricades to withstand wind, water, ice, and other elements. Project signs shall not be mounted on vehicles, buildings, walls, fences, utility poles, traffic sign posts, other public infrastructure, or trees. Project signs shall be located to achieve maximum visibility without interfering with sight distance and flow of both vehicular and pedestrian traffic.

5. PUBLIC MEETINGS

When directed by the City Engineer, Permittees shall conduct and convene one or more public meetings to inform the public about the project and answer any questions. Such meetings shall comply with all applicable laws, regulations, and City policies for public meetings, including notice of the meeting distributed in other languages or formats as appropriate for the area affected. One electronic copy and two hard copies of the minutes from each public meeting shall be delivered to the City Engineer within five (5) business days of the date the meeting was held.

8.3 NEW YORK STATE INDUSTRIAL CODE RULE 53

New York State Industrial Code, Rule 53 (“Code Rule 53”), Part 753 of Title 16 of the Codes, Rules, and Regulations of the State of New York (16 NYCRR Part 753), regulates construction, Excavation, and demolition sites located at or near underground facilities in order to ensure safety and prevent damage to public and private property. All Excavators and operators of underground facilities are required to comply with Code Rule 53.

1. STAKE OUTS

Before commencing or engaging in any non-emergency Excavation or demolition, each Excavator shall request a Stake Out from Dig Safely New York (call 811) at least two (2), but not more than ten (10) business days (not including the date of the call), before the commencement date of the Excavation or demolition.

At least seven (7) business days in advance of the commencement date of a demolition, the Excavator shall request a pre-demolition conference through the one-call notification system.

In case of emergencies that require immediate Excavation, the Permittee or Excavator is obligated to contact Dig Safely New York and request an emergency Stake Out as soon as possible.

2. REPORTING DAMAGE

Excavators shall take all reasonable precautions to prevent damage to underground facilities. The Excavator shall immediately report to the underground facility’s owner any damage to a facility or when the Excavation reveals any danger of failing.

Any work in the immediate area of the damaged facility shall be suspended until such damaged portion is repaired. The repair of a damaged underground facility shall be performed by the owner or others authorized by the owner. Any damage to the City’s street lighting or water distribution systems must be reported to Street Lighting or the Water Dispatcher, respectively.

3. EMERGENCY REQUIREMENTS

In the event of any abnormal condition which presents immediate danger to life, health or property, including discontinuance of a vital utility service necessary for the maintenance of public health, safety and welfare, the Excavator shall:

- a. Proceed to evacuate all employees and persons from the immediate vicinity;
- b. Immediately call 911 and report the location, nature of the emergency, and the affected underground facility; and
- c. Immediately contact the operator of the affected facility and report the location, nature of the emergency, and the affected underground facility.

8.4 LABOR AND MATERIALS

Permittee shall be responsible for ensuring that completed work complies with the Permit; that competent, qualified personnel perform all phases of the Work; that suitable equipment for the job is used; that only appropriate materials approved by the City Engineer are incorporated in the restoration work; and that all chemical and physical properties meet the relevant specifications found in the *City of Rochester Standard Construction Documents – Specifications and Details*.

8.5 USE OF WORK AREA

1. Safe Work Area Requirements

Permittee shall take every reasonable precaution to prevent injuries to persons or damage to property. Permittee shall comply with all applicable rules, regulations, and standards governing work place safety, including those of the U.S. Department of Labor Occupational Safety and Health Administration (OSHA) and New York State.

2. Maintenance of Storm Water Runoff

Storm water runoff facilities (i.e. swales, culverts, gutters, inlets, catch basins, laterals, etc.) in and next to the Work Area shall be maintained for the duration of the Permit Work to provide sufficient surface drainage.

3. Equipment and Materials Storage

All equipment and materials shall be stored in a safe location when not in use and at the completion of each work day. No equipment or materials shall be stored in the Right-of-Way unless specifically authorized by the Permit.

Any proposed storage in the Right-of-Way shall be included in the Maintenance and Protection of Traffic Plan and approved by the Permit Office. Storage locations allowed in the Right-of-Way shall be marked off with proper warning devices (i.e. fluorescent orange safety fencing, barricades, flashers, etc.).

Storage on a vacant parcel requires Bureau of Buildings and Zoning approval. If a City-owned vacant parcel is to be used, approval is required from the City's Real Estate Office.

Storage of equipment and materials shall not present a hazard, nuisance, or unreasonable inconvenience to the public. Storage shall be in a location that does not block pedestrian or vehicular access, impede sight distances at driveways or intersections, obstruct traffic control devices, or pose any risks to public safety.

Storage on grass medians and malls is not permitted, nor shall equipment or materials be placed on any tree root system. Vehicles and construction equipment shall not be left idling beneath any tree canopy.

Any materials or equipment vandalized with graffiti must be repainted, cleaned off, or removed from the Work Area within twenty-four (24) hours to keep the Work Area graffiti-free.

Storage of equipment and materials shall not interfere with the progress of other contractors or the City of Rochester.

If the storage location is relocated as the Permit Work progresses, the original storage location shall be cleaned-up and temporarily restored to a non-hazardous, smooth, usable surface within one (1) Day of discontinued use. Upon completion of Permit work, the location shall be restored to its original condition or better.

Contractor and subcontractor vehicles and construction equipment must be clearly marked with the company name. Temporary magnetic signs are acceptable.

4. Tree Protection

It is the responsibility of the Permittee to protect all trees that are located within the Work Area to minimize any possible damage due to construction activities. Permittee shall comply with the requirements of City Code section 89-9 and 89-10 regarding trees and landscaping requirements. Permittee is subject to all applicable penalties for failure to do so, including those authorized by City Code section 89-12.

a. **Equipment and Materials Storage**

As stated in section 3 (above), equipment, materials, or excavated spoils shall not be placed within the canopy of any tree to prevent smothering of the tree root system and damage caused by construction equipment. Vehicles and construction equipment shall not be parked on any tree root system, nor left idling under any tree canopy.

b. **Fencing**

Permittee is to provide tree protection in the form of fencing to protect all trees within the Work Area against any cutting, breaking, skinning, or bruising of tree roots, bark and branches. Protective fencing shall be installed before any construction activities commence and shall remain in place until the Permittee performs the final grading and seeding operation. Fencing shall be placed at the outer limits of the tree's canopy.

Fencing material may be either fluorescent orange construction/safety fencing, or wood rail and post. All fencing shall be at least four (4) feet high, firmly anchored and plumb.

c. **Tree Root Cutting**

Where tree root cutting is conducted, it shall be with sharp cutting tools. Exposed tree roots are to be immediately covered with wet burlap and re-buried as soon as possible. Where the City Forester has determined that extensive cutting of the tree root system has occurred, the Permittee shall

ensure that the tree root system receives between one half (½) inch and one (1) inch of water over the tree canopy area on a weekly basis for the duration of the Permit Work.

d. Tree Damage

If a tree is damaged or branches broken by construction activities, the Permittee shall trim the branch or wound within three (3) Days of the damage, shall employ current arboricultural standards for appropriate care, and shall immediately notify the City Forester's office (585-428-7581). Those trees that the City Forester's office determines are damaged beyond repair shall be removed and replaced with a new tree, as specified by the City Forester, at the Permittee's sole expense.

e. Utility Installation

The least disruptive means of installing underground utilities is a combination of trenching and tunneling. Where there is insufficient space to bypass the canopy of the tree by open trenching, tunneling is to be used.

Tunneling requirements are as follows:

Tree Diameter (DBH)	Minimum Distance of ends of Tunnel to Tree Trunk	Minimum Depth of Cover Over Tunnel
less than 10"	6'	2½'
10" to 14"	10'	3'
15" to 19"	12'	3½'
20" and over	15'	4'

5. Protection of Survey Monuments

The protection of all Survey Monuments within the Work Area is the responsibility of the Permittee. Survey monuments include all Rochester City and Topographical Survey Monuments (horizontal and vertical) and United States Coast and Geodetic Survey Monuments. Permittee is responsible for the protection of the Survey Monuments from the start of the Permit work until a representative of the City's Maps and Surveys Office has inspected and accepted the conditions of the Survey Monuments after work is completed.

When Survey Monuments are within the Work Area, Permittee must contact the City's Maps and Surveys Office to verify that the necessary reference control points ("ties") have been taken on all existing monuments which will be impacted prior to the start

of any Permit work. The City's Maps and Surveys Office will supply the Survey Monuments' locations and Stake Out any Survey Monuments prior to the start of the Permit Work.

Permittee shall be solely responsible for replacement of any destroyed Survey Monuments. Monuments shall be replaced as directed by the City's Maps and Surveys Office. The City's Maps and Surveys Office is available to answer questions relating to monument replacement work.

A monument shall be considered destroyed when:

- It has been moved more than 0.02 of a foot in any direction from its City-tied position;
- It is broken;
- It has been disturbed to point that survey monument's position is no longer fixed or stable;
- It has been excavated and removed from ground for any reason; or
- It has been vertically adjusted without prior written authorization of Maps and Surveys office.

The determination that a monument has been destroyed shall be in the City's sole discretion.

6. Protection of Historic Features

Preservation of historical street features is required when performing work in the Right-of-Way. The protection of all historic features in the Work Area is the responsibility of the Permittee.

Articles of historical or scientific value, including but not limited to coins, fossils and articles of antiquity that may be uncovered by the Permittee shall become the property of the City of Rochester. Such findings shall be reported immediately to the Permit Office who will determine the method of removal, when necessary, and final disposition thereof.

7. Daily Site Clean-Up

Any person, contractor or Agency performing work in the Right-of-Way shall cleanup the Work Area on a daily basis, including the removal of debris and any excess construction materials.

Dusty conditions shall be controlled daily by appropriate methods such as sweeping or watering the site when warranted or as directed by the Permit Office.

All spoil material shall be removed from the job site daily to promote a clean job site. No Excavation shall proceed or continue unless the proper spoil material removal transportation equipment is available. Spoil material shall be cleaned off equipment tires before leaving the Work Area. A hose down area shall be established, if required.

There shall be no spoil material stockpiling within the Right-of-Way upon completion of the work Day.

8. Noise

Permittees shall comply with Chapter 75 (Noise) of the City Code when performing work in the Right-of-Way. Construction activities that create excessive noise are not permitted between the hours of 10:00 p.m. and 7:00 a.m. on any Day of the week, unless a variance is granted in advance by the local Neighborhood Service Center where the work occurs.

8.6 MAINTENANCE AND PROTECTION OF TRAFFIC PLAN

All Permit work shall have a Maintenance and Protection of Traffic Plan that is jobsite-specific and addresses all five parts of the Work Area as described below.

All traffic control devices and their placement shall comply with the Federal Highway Administration (FHWA) *Manual on Uniform Traffic Control Devices (MUTCD)* and the New York State Department of Transportation's *Supplement to the Manual on Uniform Traffic Control Devices (MUTCD Supplement)*. These documents may both be found on New York State's website at: www.dot.ny.gov/mutcd

The Maintenance and Protection of Traffic Plan shall provide traffic maintenance for the entire Work Area and shall be approved before a Permit is issued. This plan shall include Work Area signage, a description of the scope of work, construction phases, and a construction Schedule.

For Permit work of less than two weeks in duration, the City Engineer may review and approve the Maintenance and Protection of Traffic Plan. For work durations of two weeks or greater, the plan must be approved by the Traffic Control Board.

Public streets that are designated as arterial and collector streets generate a significant amount of vehicular traffic, especially during peak rush hours. **NO WORK IS TO OCCUR ON THESE STREETS DURING THE HOURS OF 7:00 A.M. to 9:00 A.M. and 4:00 P.M. to 6:00 P.M. ON WEEKDAYS.** The streets are to remain open and fully accessible during these hours to maintain adequate vehicular traffic flow. Restrictions may be lifted by the City Engineer for a short term period that does not exceed two (2) weeks in duration. Traffic Control Board approval is required for long term periods that exceed two (2) weeks in duration.

The Maintenance and Protection of Traffic Plan shall address and comply with the following:

1. Vehicular and Pedestrian Access and Safety

Permittees shall provide and maintain safe travelled ways at all times. Traffic shall be allowed to proceed safely within and through the Work Area, or when approved, along established detour routes to redirect through-traffic around the Work Area.

A safe travelled way shall include, but not be limited to the following:

- a. Work Area delineation devices that address the five parts of a work Area (Advance Warning Area, Transition Area, Buffer Space, Work Space, and Termination Area);
- b. Flaggers to provide adequate traffic control, when necessary. (Note: OSHA requires flaggers to have hard hats, reflective safety vests and reflective flags);
- c. A hard, smooth, clean and dust-free paved surface that is free of potholes, bumps, or other irregularities and obstructions that allows for unimpeded non-hazardous passage of traffic; and
- d. Emergency vehicle access to all properties on a street whether it is closed to traffic or not.

Public sidewalk areas shall be provided on at least one side of the street at all times, with proper signage in place to direct pedestrians. Pedestrian routes are to be fully accessible for persons with disabilities, and provide for crossing an intersection in two directions. All pedestrian routes must be a minimum of five (5) feet wide.

Bus stop and other public transportation areas shall be maintained and accessible at all times. Any changes to bus stop or public transportation areas and signs shall be coordinated with the Regional Transit Service. A temporary public transportation area shall be provided when the existing public transportation area is disturbed or inaccessible due to construction activities. A five-foot (5') wide paved passage shall be provided between the sidewalk and curb. The paved passage shall consist of either two (2) inches of asphalt or three (3) inches of concrete. Existing bus stop signs shall be relocated to the temporary bus stop, and relocated back to the permanent location immediately upon completion.

2. Sign Maintenance

Permittee shall place and maintain work zone signage in accordance with the *FHWA MUTCD* and the *NYS DOT SUPPLEMENT* before starting work. All signs and barricades shall be in their proper place and checked before daily construction starts, as daily work progresses, and at the end of the work Day. Signs and barricades not in use shall be temporarily covered or removed from the work site and stored at an approved storage area. Any existing signs that are removed shall be reinstalled by the end of each work Day.

3. Driveway Access

Permittees are required to notify residents and businesses in writing at least five (5) Days before closing driveway access. Alternate driveway access must be maintained for businesses at all times. If alternate driveway access is not possible, driveway closings must be coordinated with the business to minimize the impact on its operations.

4. Fire Hydrant and Alarm Access

The Permittee shall maintain clear visual and physical access to fire hydrants and alarms. This access shall be free of any obstructions and/or hazards throughout the work Day and after work hours. The surface adjacent to these devices shall be kept graded and compacted. Only minor interruptions to this access resulting from operations that cannot be prevented will be allowed.

5. Protection of Excavations and Hazardous Locations

All Excavations and hazardous locations shall be adequately protected with barricades to be reasonably safe and inaccessible. Barricades may consist of timber curbing with fencing, jersey barriers, or other appropriate protective devices, and shall be installed and maintained in good, non-hazardous, and graffiti-free condition. Fence posts shall be firmly anchored and plumb, and all fencing material must be tight and firmly attached. Flashers and reflective materials shall be securely attached to any barricades placed in the roadway.

6. Steel Roadway Plating

Steel plates shall be manufactured specifically for road plating, rated for HS20-44 loading, be a minimum of one (1) inch thick, and shall completely cover and overlap the Excavation by a minimum of 12 inches all around. Steel plates may remain in place as long as work is actively progressing at the site. If the work is stopped for more than fourteen (14) Days, the steel plates shall be removed and the Excavation backfilled and temporarily restored.

Steel plates are to be level and non-rocking, and pegged in place to prevent any movement. Edges of steel plates shall be ramped all around with asphalt.

During the winter season (November 1st to April 14th), the City's Special Services Dispatch Office shall be notified of the location and dates of when steel plates are to be used in the Right-of-Way. A warning sign stating "RAISE PLOW ROAD PLATE 20 FT AHEAD" shall be installed facing traffic in all directions twenty feet ahead of all plated Excavations. The sign shall be placed two (2) feet off of the Pavement edge with the bottom of sign being a minimum of five (5) feet above grade. The sign is to be located to achieve maximum visibility without interfering with sight distance for motorists and pedestrians.

Permittees shall contact the City's Special Services Office the Day the steel plates are removed.

8.7 TRAFFIC CONTROL BOARD APPROVAL

Traffic Control Board approval is required for the following projects, in accordance with the terms of City Code section 111-83. A Permit will not be issued until Traffic Control Board approval has been given to the Permit Applicant.

Traffic Control Board approval is required for certain projects, including:

- New driveway openings in the Center City District as identified in Code section 120-66;
- Alterations of existing driveway openings in the Center City District;
- Recessed parking areas;
- Projects with Maintenance and Protection of Traffic Plans having a construction duration of two weeks or greater;
- Modification of any street geometry, including width, and lane configuration;
- Modification of parking or traffic control regulations.
- Street Closures
 - The legal closing of a street as a passageway for the general public will be done only upon authorization of the City Engineer. Whether a street is closed or not, the Contractor shall at all times of the day and night provide a safe passageway for the use of vehicular and pedestrian traffic to and from properties along the street. Such passageways shall be adequately maintained and if required provided with proper signs, barricades, lights and/or flagging personnel.

Applicants should allow a minimum of three weeks to schedule their proposal at a Traffic Control Board meeting.

8.8 PUNCH LISTS

When required in the Supplementary Conditions of the Permit, the Permit Office shall conduct a final walkthrough inspection with the Permittee, the Construction Project Manager, and a representative of any involved utility agencies. The Permittee shall contact the Permit Office within five (5) Days of work completion to schedule the final inspection and request the issuance of a punch list. Permittee is responsible for the completion of the final punch list items within fifteen (15) Days of its issuance.

8.9 AS-BUILT DRAWINGS

Permittee shall maintain accurate maps and other relevant records of its facilities as they are actually constructed in the Right-of-Way. Unless waived by the City Engineer, in writing, Permittees shall submit as-built Drawings which shall be referenced to the New York State Plane Coordinate System, NAD83 Transverse Mercator projection, Western Zone and shall include a minimum of five (5) swing and angle ties to all monuments within the project area.

When required in the Supplementary Conditions of the Permit, Permittee shall provide to the Permit Office one (1) complete set of certified, reproducible, as-built Drawings, as well

as a digital copy of such Drawings within thirty (30) Days of work completion. The as-built Drawings must be thirty-four inches by twenty-two inches (34" x 22") in size, scalable, and be stamped and signed by a New York State Licensed Professional Engineer. The reproducible as-built Drawings shall consist of one (1) complete set on Mylar.

The digital set of the as-built Drawings is to be provided on CD or USB flash drive in PDF format and in Microstation V8i DGN or Autodesk(R) DWG format or such other format as required by the City.

The certification is to be type-written, signed by the Permittee, and notarized, and shall state: *"These Drawings have been prepared utilizing all available information, and to the best of our (my) knowledge represent "as-built" conditions."*

8.10 GUARANTEE, TESTING, AND FAILURE

1. Guarantee

A Permittee making Excavations in the Right-of-Way shall guarantee its permanent restoration work performed for a period of two (2) years from the date the project was deemed to have passed the City's inspection (date of acceptance). The Permittee shall completely re-excavate, refill, and repave any permanent restoration that fails within the two (2) year guarantee period. In the event that Permittee is required to re-excavate, refill and repave a failed restoration, the City Engineer may require the Security required by Chapter 104 and described above to be continued for an additional two (2) years. Further, the restoration work shall be subject to a renewed two-year permanent restoration guarantee period.

2. Testing of Work

The City Engineer has the right to order a test on any restoration of the Right-of-Way to determine if the work has been completed in accordance with City Specifications.

3. Penalty for Failure

If the test shows the restoration to be unacceptable, the Permittee must pay the cost of the testing and any penalty charges, in addition to making the proper restoration. If the Permittee fails to perform the proper restoration, the City shall do the work and assess all costs plus a fifteen percent (15%) administrative charge and ten percent (10%) RPR Inspection fee to the Permittee. The City may draw on the Security to pay for the restoration work, fees, and penalties. In cases of noncompliance, no additional Permits will be issued to the Permittee until any previous unacceptable work has been properly restored and any unpaid fees, penalties or charges have been paid.

9 TELECOMMUNICATIONS

9.1 PURPOSE

The City supports the deployment and expansion of telecommunications facilities, networks and associated technology in the City of Rochester Right-of-Way. These Rules and Regulations establish an efficient and seamless permitting process, while allowing the City to obtain necessary information and to properly review applications. This section addresses all telecommunications facilities and equipment in the Right-of-Way for the purpose of ensuring safe, suitable, and appropriate installations in public spaces.

Applicability: The entirety of the Rules and Regulations applies to telecommunications installations, however where there are any conflicts or inconsistencies between this section and the remainder of the Rules and Regulations, this section shall control. Words and terms defined in the Telecommunications Code shall have the same meaning when used in these Rules and Regulations.

9.2 GENERAL INFORMATION

The City has adopted a telecommunications code, the Telecommunications Code of the City of Rochester (“Code”), Chapter 106, available online at www.cityofrochester.gov/citycode/. All Permit Applicants should familiarize themselves with the Code requirements as well as these Rules and Regulations.

Section 704 of the Telecommunications Act (“TCA”) of 1996 (Public Law 104-104) recognizes local authority over wireless communications facilities regarding placement, construction, and modification.

The FCC regulates radio frequency (RF) emissions, and establishes comprehensive rules for maximum permissible exposure levels (the “FCC Guidelines”). State and local governments cannot:

- (1) Regulate wireless facilities based on environmental effects from RF emissions when the emissions conform to the applicable FCC Guidelines or
- (2) Establish RF exposure standards.

However, the FCC permits local governments to require an applicant to demonstrate compliance with the FCC Guidelines as a prerequisite for Permit approval. Those compliance requirements are detailed below.

9.3 PERMIT APPLICATION POLICY

REGISTRATION REQUIRED:

Permit Applicants shall be required to complete the Registration Application Requirements, as set forth in Code section 106-5, prior to submission of a Permit application. Applicants are encouraged to participate in the Optional Pre-Application Review process described below

and begin negotiations for a Master License Agreement, concurrently or as soon as possible after submission of a registration application.

FORMAT REQUIRED:

All Permit applications shall be made on City-approved forms with the attachments detailed below. Forms are available at the Permit Office. Further information is available online at: <http://www.cityofrochester.gov/rowpermits/>.

SCALE: All Drawings, plans, and other visual representations submitted with the application shall be to scale, no exceptions. The City's standard scale is one (1) inch = twenty (20) feet, unless otherwise specified.

COMPLETE APPLICATION:

A Permit application shall be deemed complete when all information, plans, reports and other requirements of section 7, the general requirements for all Right-of-Way permit applications and section 9.5, the additional requirements for telecommunications facilities and equipment permit applications, of the Rules and Regulations and any other information requested by the City Engineer have been submitted in full.

DATE OF RECEIPT:

All complete Permit applications will be deemed submitted on the date received electronically at the following email address: DESPermitOffice@CityofRochester.gov, or five Days after the date of postal mailing, or on the date stamped on the documents by the Permit Office if hand-delivered. However, a complete Permit application is submitted prior to the date the Applicant has completed the registration requirements of Code section 106-5, the Permit will be deemed complete and submitted as of the date the registration is complete.

OPTIONAL PRE-APPLICATION REVIEW:

Applicants have the option to submit a summary description of the proposed scope and scale of their project prior to submitting the individual Permit applications. The City will review the plan and contact the Applicant with questions and comments. Applicants are encouraged to submit this information to ensure the City can dedicate sufficient time and resources to the proposed installations in the Right-of-Way and to expedite the Permit approval process.

- The summary description should minimally include the nearest street address, and latitude/longitude of each proposed location.
- The applicant should provide prioritization of the locations submitted for review.

9.4 RIGHT-OF-WAY REGULATIONS

The City of Rochester owns all street lights within the City. City street lights are connected to an unmetered service that is not available for telecommunication facilities. Metered services are required for street light pole-mounted telecommunication facilities.

POLE TYPES AND AVAILABILITY

1. Available:
 - a. City owned poles (metal, fiberglass or wood):
 - i. Replace pole with galvanized powder coated steel pole
 - ii. Decorative/Ornamental or Sensitive Location - shall match the existing style, design, height, size, and color of surrounding poles
 - b. Utility owned wood pole
 - i. Determined by Utility and City - Contact City Permit Office
 2. Not Available
 - a. Traffic signal poles are owned by Monroe County
 - b. City has the right to withhold certain locations for its own use
 3. By Special Approval Only
 - a. New Small Cell Only pole - typically not allowed - by special approval only
- **POLE HEIGHT:** Poles over 35 feet high shall not be permitted in the Right-of-Way. Pole height shall be restricted for reasons of public safety, including snow and ice shedding, excessive fall line, excessive excavation and installation requirements, and traffic safety concerns, unless otherwise approved in writing by the City Engineer.
 - **ANTENNA & EQUIPMENT HEIGHT:** Attachments to a pole or other structure in the Right-of-Way, including antennas and other telecommunications equipment shall not exceed a total pole height of 40 feet, unless otherwise approved in writing by the City Engineer.
 - **NEW POLES:** For traffic safety and other Right-of-Way management reasons installing new poles, excluding replacement poles, in the Right-of-Way shall not be permitted unless the Applicant demonstrates that no other suitable location will provide reasonable coverage/capacity for its telecommunications network. Where such a claim is made, Applicant shall pay the costs of a neutral telecommunications engineering expert to review the information provided in support of the Applicant's claim. Any new pole shall, in the City's sole discretion, be dedicated to the City and situated so that the location is safe, does not obstruct pedestrian or vehicular traffic, and meets all applicable legal requirements.
 - **REPLACEMENT POLES:** Any City-owned poles replaced by the Permittee, including replacement with Smart Poles, as described in section 9.17 below, shall be dedicated to the City upon installation. Any replacement poles shall match the existing style, design, height, size, and color of surrounding poles unless such requirement is otherwise waived by the City Engineer in writing.

- **WOODEN POLES:** Telecommunications facilities and equipment shall not be installed on City-owned wooden poles. Applicants seeking to install their facilities or equipment at a wooden pole location shall replace the wooden pole with a new, fully-integrated galvanized steel pole or such other pole approved by the City Engineer. Such poles shall be dedicated to the City upon installation.
- **PROHIBITION ON ADDITIONAL LIGHTS:** Installations in the Right-of-Way shall not include any new lights, flashing or otherwise, without express approval of the City Engineer, based on a determination that the lights will not interfere with driver attention or pose safety or light pollution issues.
- **EQUIPMENT BOXES:** Equipment and other boxes shall not be installed at ground-level in the Right-of-Way unless specifically authorized by the City Engineer, based on a determination that there are no reasonable alternatives. Costs of undergrounding may be considered but may not be the sole basis for such determination with respect to equipment to be located within a Sensitive Location. Boxes and equipment at ground-level shall be screened or camouflaged in a way that is compatible with the character of the area.
- **MOCK-UPS:** Where the Applicant does not use equipment pre-approved by the City, the applicant may be required, in the City Engineer's sole discretion, to design a mock-up of the installation in advance of performing any work. The Permit may be granted with the condition that work may commence only after the mock-up is approved.
- **LOCATION OF FACILITIES:** Telecom providers shall first consider whether installations on collector and arterial streets will provide sufficient telecommunications coverage/capacity before requesting residential or Sensitive Location installations, and shall provide the City Engineer with a justification explaining why installations on nearby collector or arterial streets would not provide reasonable telecommunications service and include, if applicable, coverage maps or an engineering study documenting a capacity gap.

9.5 PERMIT INFORMATION REQUIRED

Applications for telecommunications Permits shall include:

- Completion of the registration application as required by Code section 106-5.
- Submission of all permit application requirements as set forth in section 7.1
- The nearest street address to the proposed installation;

- Project description including where equipment will be placed, whether poles or other infrastructure will be replaced, what equipment will be used, etc.;
- An elevation sheet clearly showing any new Excavations or a notation stating that no Excavation is necessary;
- An elevation sheet clearly showing any new surface-mounted equipment or facilities (boxes, electric meters, disconnect switches, etc.) within 100 feet of the pole or installation, or a notation indicating that no equipment is proposed at surface-level;
- An elevation sheet that describes the sizes of the equipment at the top of the pole or antenna, whichever is higher;
- An elevation sheet for all poles showing that cabling will be located inside the pole and equipment will be flush to the pole;
- The owner of the pole;
- The location of all node identification stickers and radio frequency warning stickers;
- Clear details about the color and finish of all visible equipment, including but not limited to antennas, brackets, cabling, electric meters, disconnect switches, and equipment boxes;
- All equipment specifications, including equipment names, model numbers, sizes, and colors (equipment sheets providing this information may be attached in lieu of a narrative description from the applicant);
- A copy of the radio frequency (RF) emissions report stamped by a New York State licensed engineer;
- Identification of all equipment or facilities that will be located in a Sensitive Location;
- A detailed list of any potential safety issues, including but not limited to whether the installation is near a highway, whether tree branches will interfere with equipment, whether ice shedding is a potential hazard, or whether equipment will restrict access to a sidewalk or pedestrian walkway;
- Whether ice removal, vegetation removal, or other regular maintenance will be required throughout the calendar year;
- Description of the transmission medium that will be used to offer or provide telecommunications services;
- If applicant is proposing an underground installation within new or existing ducts or conduits, information in sufficient detail to identify:
 - The excess capacity currently available in such ducts or conduits before installation of applicant's facilities; and
 - The excess capacity, if any, that will exist in such ducts or conduits after installation of applicant's facilities.

In addition to information required on the application itself or required by ordinance, each Permit application for telecommunications facilities in the Right-of-Way shall include:

1. A detailed list of all equipment the Applicant anticipates using for the project; and
2. Actual measurements, weights, heights, and other details of each piece of the proposed equipment; and
3. A detailed description of the exact location proposed for installation of the equipment, including whether the equipment will be installed aerially, underground, or at street level, including any facilities or equipment to be installed for the City as alternative compensation, pursuant to Code section 106-16;
4. Copies of the original construction or engineering Drawings to scale;
5. Photo simulations copied onto the plan set in legible format;

Additional Drawings, photographs, mock-ups, and other information shall be made available to the City upon request.

9.6 INFORMATION REQUIRED POST-INSTALLATION

After work is complete, Permittee shall provide to the City's Permit Office within 30 business days:

1. As-built drawings, as specified in Section 8.9;
2. A GIS map of the overall completed installation, as specified in Section 9.19, GIS Maps.
3. Photographs from at least four different side-views, an aerial view, if required by the City Engineer, and a ground view of:
 - a. the proposed installation/Work Area prior to any work or installation commencing;
 - b. each piece of equipment as installed;
 - c. the overall completed installation;
4. A sworn certification from the Permittee that all work was done in accordance with the Permit and Master License Agreement; and
5. Inspection availability for an in-person inspection with City staff to observe the final product and ensure Permit compliance.

9.7 ANNUAL INSPECTION CERTIFICATION

On July 1st of each year, Permittee shall submit to the Permit Office a sworn certification, with a photograph of each site, that it has completed an inspection of all of its installed facilities on a specific date within the prior three months, that all facilities are in compliance with the

permit, applicable laws, agreements, and these Rules and Regulations, and that such facilities do not pose any threat to health and safety.

Should Permittee discover that any facilities are in need of repair, it shall document such locations and repairs needed on the certification form. If the installation poses a safety risk, Permittee shall immediately contact the Permit Office and immediately secure the area to prevent injury.

If Permittee has abandoned any facilities and has not yet effected removal, it shall indicate the location of the abandoned facilities on the certification form. Permittee shall certify that such facilities do not pose a safety risk. This requirement does not replace any other requirements in the City Code, Master License Agreement or these Rules and Regulations governing notification or responsibilities related to abandoned facilities.

9.8 PERMIT EXPIRATION

Each Permittee must complete work authorized by a Permit within six (6) months of the Permit date or lose authorization to access the Right-of-Way. Such requirement is necessary to promote progress, efficient planning, and equal access to the Right-of-Way.

Upon good cause shown as to why installation has been delayed (e.g., unusual weather, prohibitive conditions, natural disasters, etc.), Permittee may request a permit extension for up to three months, from the City Engineer. Permittee shall pay any associated fees and costs for such extension. If the extension is denied, the Permit shall expire and the Applicant will be required to reapply and pay a new Permit fee.

9.9 PERMIT NON-COMPLIANCE

Where a Permittee fails to comply with a Permit, the Permit shall be revoked in accordance with Code section 106-18 and 106-19. Upon revocation, including the completion of any appeals process, in the City Engineer's sole discretion, the Permittee shall remove all equipment and facilities. If Permittee wishes to continue the project, it must reapply and pay a new Permit fee. If a Permittee's non-compliance is determined by the City Engineer to be intentional or is repetitive, as evidenced by installation of multiple unauthorized equipment or facilities or installation of equipment of a size or design not authorized by the Permit, etc., the City Engineer may revoke all applicable Permits and decline to act on any new permit applications for similar equipment or facilities until Permittee has completely removed the non-complying equipment and facilities from the Right-of-Way and has reasonably assured the City Engineer that authorized equipment and facilities will be installed. Permittee will be liable for all associated penalties and fees arising out of its non-compliance.

9.10 GENERAL INSTALLATION REQUIREMENTS AND RESTRICTIONS

- All node identification stickers (including carrier name and phone number) must be placed on the underside of equipment enclosures;
- All radio frequency warning stickers shall be placed directly below any antennas, not near ground-level on the pole;
- There shall be no outside or exposed cabling;

- Equipment shall not extend more than a total of twelve inches (12”) from the pole when observing the equipment from any angle (e.g. six inches on either side of the pole or 12 inches from only one side of the pole and zero inches from the other, etc.);
- No equipment or facilities which exceed 90% of the pole’s capacity shall be permitted. Load shall not be calculated generically, but shall be calculated based on the actual pole at issue, taking into consideration all relevant factors (e.g. age, wear, annual exposure to road salt, extreme weather, etc.). At the City Engineer’s request, Permittee shall submit a sealed engineer’s report confirming that Permittee’s equipment and facilities meet this requirement;
- All installations shall comply with applicable emissions standards;
- No installations of any telecommunications facility, including aerial fiber, optic strand-mounted wireless and Wi-Fi equipment, shall be within five feet of a door or window, nor placed in front of any window unless the Permittee establishes that there is no reasonable alternative to such installation.
- All node identification and warning labels shall be installed on all devices as required by codes and standards. Labels (including carrier name and phone number) must be placed on the underside of equipment enclosures;
- All radio frequency warning labels shall be placed directly below any antennas, not near ground-level on the pole;
- There shall be no outside or exposed cabling;
- Equipment shall not extend more than a total of twelve inches (12”) from the pole when observing the equipment from any angle (e.g. six inches on either side of the pole or 12 inches from only one side of the pole and zero inches from the other, etc.);
- All installations shall comply with applicable state and federal rules and regulations, and emissions standards;
- Equipment shall be installed on pole structure or underground; ground-level installations are not permitted except by special approval;
- Equipment shall not cause any interference with operation of facilities, including signs, banners, festoon circuits, and miscellaneous lighting.
- The maximum quantity of added equipment enclosure on a single pole shall not exceed four (4) including electrical meter and disconnect switch;
- Finish color of equipment shall match pole unless otherwise approved;
- No equipment or facilities shall exceed 90% of the pole’s capacity. Load shall not be calculated generically, but shall be calculated based on the actual pole at issue, taking into consideration all relevant factors (e.g. age, wear, annual exposure to road salt, extreme weather, wind speed, etc.). Permittee shall submit a engineer’s report, sealed by a professional engineer registered in New York state, confirming that Permittee’s equipment and facilities meet this requirement;
- No installations of any telecommunications facility, including aerial fiber, optic strand-mounted wireless and Wi-Fi equipment, shall be within five feet of a door or

window, nor placed in front of any window unless the Permittee establishes that there is no reasonable alternative to such installation;

- All City Street Lighting electrical wiring, splices and connections must be performed by Licensed Master Electrician. Street light cables and wires shall be replaced and connected to same unmetered source used prior to pole replacement unless directed otherwise by the City Engineer;
- Metered electrical services are required for facilities mounted to City owned street light poles.

Permittees shall comply with the additional requirements and restrictions found in the City of Rochester Standard Construction Documents – Specifications and Details.

9.11 NOISE RESTRICTIONS

Facilities and equipment shall not generate more than 45 decibels of sound within a three (3) foot radius from the center of the pole, or at a distance of three (3) feet from the closest building wall of any residential, retirement, convalescent, or other living facility; or from any public library, school, or child care facility. Facilities and equipment in other locations shall not generate any more noise than is reasonable for the area. Such determination is at the sole discretion of the City Engineer after considering the location of the installation and character of the neighborhood in relation to the decibels produced.

Noise studies shall be performed within seven business days after a written request from the City Engineer. Such studies shall be performed at the Permittee's sole expense. Violations of these noise requirements or failure to timely perform testing will be considered a breach of the Permit and the City will have the authority to immediately remove the equipment and facilities at Permittee's cost.

Permittees shall provide to any resident living within 300 feet of a telecommunications facility or accessory equipment, complimentary noise testing from their home, at the resident's request, up to once per year.

9.12 RADIO FREQUENCY EMISSIONS TESTING

Upon request, the Permittee shall provide complimentary RF testing to any person residing in or owning a home or business within 500 feet of a telecommunications facility. Such testing may be requested at least once per year for the life of the installation.

9.13 MODIFICATIONS TO EXISTING FACILITIES AND EQUIPMENT

Any modifications to equipment and facilities not authorized by the Permit shall require a new Permit. Applicant shall pay all appropriate Permit fees associated with the new Permit.

9.14 SIGNIFICANT GAPS

Any evidence or documentation regarding a significant gap in coverage or capacity shall be provided from the telecommunications carrier itself, not the installing party.

9.15 NEW TECHNOLOGIES AND INSTALLATION METHODS

New technologies or installation methods (i.e. microtrenching, etc.) that are not specifically addressed in the City Code or these Rules and Regulations may be approved by the City Engineer. Applicants may schedule a meeting with the City Engineer to discuss options before submitting a Permit application. The City may consider a limited pilot program upon agreement of the parties for the assessment of safety, feasibility, and to address other concerns before approving such technology or methods for long-term installation or use.

9.16 TRAINING

As requested by the City, the Permittee shall host on-site training and orientation to its facilities and equipment for City staff. The training shall include occupational safety, personal protection, proximity limits, emergency procedures and contact information.

9.17 GENERAL DESIGN STANDARDS FOR FACILITIES IN THE RIGHT-OF-WAY

POLES AND FOOTINGS: Engineering calculations stamped by a registered professional engineer licensed in the State of New York shall be provided to ensure that any existing poles and footings are adequate to support new loads. When it is determined that the existing infrastructure is not adequate to support new loads, the Applicant may propose to replace the existing infrastructure with adequate, City-approved, new infrastructure at the Applicant's expense. Such new infrastructure will become the property of the City.

ANTENNAS: Antennas and related equipment and facilities shall comply with the design standards and installation requirements set forth in these Rules and Regulations and the *City of Rochester Standard Construction Documents – Specifications and Details*. In the case of joint-use poles, the antennas shall receive approval from all necessary parties.

SIGNAGE: The only signage permitted on equipment, poles, or accessory equipment shall be as required by law or regulation. All signage shall be legible and adequately maintained. Any faded or illegible signage shall be replaced upon discovery or within thirty (30) Days of the date the Permittee received notice of the defective signage.

ENCLOSED EQUIPMENT: All cables, wires and other loose materials must be contained in conduit when underground and shall include approved tracer wire and 250 pound nylon pull cord in empty conduit, and cap or plug all opening. Such above ground equipment must be installed within embedded poles or where embedding is not possible, must be camouflaged or screened as set forth in *City of Rochester Standard Construction Documents – Specifications and Details*, as approved by the City Engineer in writing. No exposed slack or extra cable is permitted.

HISTORIC AND DECORATIVE LIGHTS AND POLES: Historic and decorative street lights or poles are not eligible for telecommunications facilities unless the City Engineer determines in writing that the proposed facilities would be sufficiently camouflaged to maintain the

character of the poles and lights at issue and the Applicant has established that there is no reasonable alternative location.

ELECTRICAL METERS: Applicant is responsible for the cost of all electrical usage and associated costs resulting from installation of telecommunications facilities. Any unauthorized use of City utilities will result in revocation of the Permit.

INSTALLATIONS ON EXISTING STREET LIGHTING OR UTILITY POLE INFRASTRUCTURE: The installation shall not increase the total height of the infrastructure by more than five feet over other similar infrastructure in the area. Unless otherwise approved by the City Engineer, antennas must be mounted to the top of the pole, or flush to the pole near the top, in a RF transparent screen that is coated or painted an approved color to match the pole. Wires and cables must run in conduit inside the pole. Underground entry into the pole through the foundation is required.

Small cell antennas on street lighting or utility poles in the Right-of-Way shall comply with the following design standards:

- The antenna and its shroud or camouflage shall be the smallest possible volume but in no case greater than three cubic feet. The antenna must be enclosed in an RF transparent screen unless a whip style antenna is used.
- Equipment, other than antennas, shall be mounted as prescribed by the City Engineer in one of the manners described below:
 - Equipment shall be mounted in a base shroud of approved design to be retrofitted to the existing light standard. The base shroud shall be coated or painted with an approved color to match the existing pole.
 - Excepting the electrical meter, equipment shall be mounted directly to the pole in an equipment box a minimum of nine (9) feet above the existing grade. The equipment box shall be coated or painted an approved color to match the existing pole and will be no wider than two times the diameter of the pole at the point it is mounted nor protrude from the surface of the pole by more than eight inches.

SMART POLES: The Applicant may propose or the City may require that the existing light standard or utility pole be replaced with a City approved pole at Applicant's cost that is manufactured with a base shroud or other attributes designed to accept wireless equipment and integrated RF screen to accept a wireless Antenna ("Smart Pole"). Smart Pole designs and specifications included in *City of Rochester Standard Construction Documents – Specification and Details* shall be deemed to meet all City camouflage requirements of the Telecommunications Code and these Rules and Regulations and Smart Pole designs not included in *City of Rochester Standard Construction Documents – Specification and Details* may meet the Camouflage requirements upon approval of the City Engineer. If purchased by the Applicant, upon installation, such poles shall be dedicated to the City. If purchased by the

City, the Applicant will be required to enter into a multi-year agreement guaranteeing the Applicant's use of the smart pole for such period of time and subject to the conditions as specified in the agreement between the Applicant and the City.

9.18 MAINTENANCE OF FACILITIES

The Permittee shall maintain all facilities installed in the Right-of-Way in a condition which maintains the safety, integrity, and aesthetics of the Right-of-Way and its facilities, including, but not limited to:

- (A) All installed landscaping must be properly and regularly maintained;
- (B) Graffiti and posters must be removed immediately or within forty-eight hours after written notification is given to the Permittee; and
- (C) Above-ground cabinets and other above-ground facilities shall not have rusty, chipped or peeling paint, have loose wires, or otherwise be deteriorated.

Ordinary maintenance or repairs in the discretion of the City Engineer shall not require an additional Permit.

9.19 GIS MAPS

Commencing April 1, 2019, and each January 1st thereafter, each Permittee of telecommunications facilities in the City shall submit, an updated GIS map of all facilities it owns or controls in the Right-of-Way. Such maps shall be submitted on CD/DVD or USB flash drive in a Geodatabase (.gdb), Shapefile (.shp), ArcGIS Layer Package (.lpx) or ArcGIS Map Package (.mpk) format to the City's Right-of- Way Permit Office.

SUGGESTED GIS LAYERS AND ATTRIBUTES:

Layer 1: Fiber Optic Cables

Attribute Name	Data Type	Description
Cable owner	Text	Manual entry of cable owner name
Fiber Count	Short Integer	Fiber count
Overhead/Underground	Text	Coded Value Domain: <ul style="list-style-type: none"> • Overhead • Underground
Cable name	Text	Manual entry of cable name
Cable type	Text	Manual entry of cable type
Cable length	Double	Cable length in feet
Glass length	Double	Glass length in feet
Date Installed	Date	Date installed in mm/dd/yyyy format
Installed by	Text	Manual entry of company/agency who installed cable
Tracer Wire	Text	Coded Value Domain: <ul style="list-style-type: none"> • Yes • No

Layer 2: Fiber Ducts

Attribute Name	Data Type	Description
Ownership	Text	Manual entry of duct owner name
Pipe diameter	Short Integer	Pipe diameter in inches

Layer 3: Fiber Nodes

Attribute Name	Data Type	Description
Structure Type	Text	<p>Coded Value Domain:</p> <ul style="list-style-type: none"> • Cabinet • Camera Pole • Conduit end point • Conduit low point • Conduit point • Dot cabinet • Electric handhole • Flume structure • FTP Box • Glycol Vault • Grate • Handhole • I/E Handhole • I/E Manhole • Junction Box • Manhole • Point of Entry • Pole • Pole Riser • Pull box • Point • Radio tower • Splice box • Termination cabinet • Traffic cabinet • Traffic handhole • Tunnel intersection • Vault
Ownership	Text	Manual entry of structure owner

Layer 4: Fiber Splice Points

Attribute Name	Data Type	Description
Ownership	Text	Manual entry of owner name
Splice enclosure type	Text	Coded Value Domain: <ul style="list-style-type: none">• Bulk head• Splice case
Installed by	Text	Manual entry of company/agency who installed cable

Layer 5: Fiber Termination point

Attribute Name	Data Type	Description
Name/Location description	Text	Manual entry of termination point description (e.g. Church @ Fitzhugh)

If a Permittee's facility map has not changed from the map submitted the previous year, in lieu of submitting a new map, it may, at its election, provide an affidavit to the City certifying that the previous year's map has not changed. The certification shall also include the date that the previous map was submitted to the City.

COORDINATION MEETINGS: Each Permittee shall participate in periodic coordination meetings with utilities, other Permittees, and affected public agencies, as requested by the City Engineer. The purpose of these meetings shall be to coordinate activity between public works projects and other work in the Right-of-Way.

9.20 CONSTRUCTION AND STANDARD OF CARE

CONSTRUCTION: The Permittee is solely responsible for construction, installation and maintenance of its facilities. The City has the right at all times to inspect the facilities to assure compliance with all Permits or approvals granted by City.

STANDARD OF CARE: The Permittee will undertake all authorized activities within the Right-of-Way in a skillful manner, consistent with the highest standards generally recognized as being employed by professionals in the same discipline in the State of New York. Facility installation activities must comply with applicable Federal, State, and local laws, regulations and rules.

9.21 ALTERNATE PAYMENT PROCEDURES

Applicant may be required to provide alternate compensation as set forth in Code section 106-15.J and 106-16, including the installation of conduit for the City whenever the Applicant is installing its own conduit and the City Engineer determines that the City needs conduit in the location and to reduce damage and disruption to the Right-of-Way. Applicant may also be requested to provide in-kind facilities or services and Applicant may offer to provide in-kind facilities or services as an alternative form of compensation, to offset some or all of the compensation owed to the City pursuant to Code section 106-15.

In all cases of alternative payment, the City Engineer shall make a written determination that the alternative compensation is in the interest of the City, including a brief description of the basis of that determination, including the need for the facilities or services by the City, the Rochester Public Library or the Rochester City School District, any benefit to the City resulting from reduced damage or disruption to the Right-of-Way and any other public benefit. If the City Engineer is able to determine the value of the in-kind facilities or services, that amount will be used as an offset against compensation owed to the City, on a one year or multi-year basis, as agreed between the Applicant and the City. If the City Engineer is unable to determine the value of the in-kind facilities or services, Applicant shall provide an evaluation of the in-kind facilities or services from an independent third-party source acceptable to the City Engineer.

Although it is preferred that alternate compensation be negotiated prior to execution of a master license agreement, alternate compensation may be required, requested or offered at any time, subject to the above Code sections and the requirements of this section. Negotiations about alternative compensation may be initiated by the City or requested by Applicants at any time, however all decisions about whether to require, request or accept alternation compensation shall be in the City Engineer's sole discretion.

10 CONTACT INFORMATION

City of Rochester	Call 311
Department of Environmental Services	
Permit Office, City Hall, Room 225B	(585) 428-6848
Maps and Surveys Office, City Hall, Room 224B.....	(585) 428-6873
Street Lighting, City Hall, Room 012A.....	(585) 428-5990
Traffic Control Board, City Hall, Room 300B	(585) 428-6828
Forester's Office, 210-B Colfax St	(585) 428-7581
Bureau of Water	
Maps and Records Office, 10 Felix Street, Room 204	(585) 428-7562
(For Emergency Notification – nights/weekends)	(585) 428-7500
Bureau of Purchasing Office	(585) 428-7041
Department of Neighborhood and Business Development	
Building and Zoning Permits, City Hall, 121B	(585) 428-6526
Real Estate Office, City Hall, Room 125B.....	(585) 428-6951
Rochester Police Department, 150 S. Plymouth, Traffic Section	(585) 428-7175
Dig Safely New York	Call 811 or 1-800-962-7962
Monroe County	
Pure Waters District Permit Office, 145 Paul Road, Building 11.....	(585) 753-7600
New York State Department of Transportation (NYSDOT):	
East of Genesee River, 938 West Linden Ave, East Rochester, NY 14445..	(585) 586-4514
West of Genesee River, 2441 S. Union Street, Spencerport, NY 14559	(585) 352-3471
Rochester City School District - Safe School Route Facilities Planner	(585) 336-4002
Rochester-Genesee Regional Transit Service	(585) 288-1700
United States Army Corp of Engineers, Buffalo, NY	(716) 879-4114

Appendix A

City of Rochester Policies and Guidelines

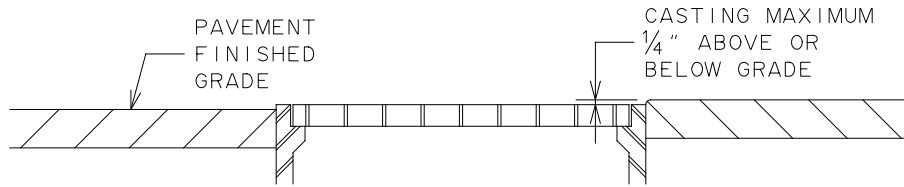

ACCEPTABLE CONDITION

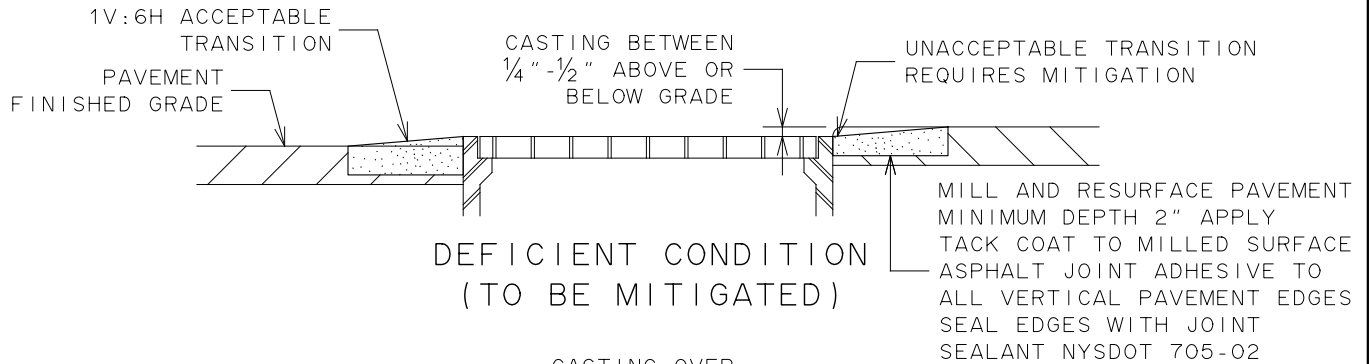

DEFICIENT CONDITION
(TO BE MITIGATED)

MILL AND RESURFACE PAVEMENT
MINIMUM DEPTH 2" APPLY
TACK COAT TO MILLED SURFACE
ASPHALT JOINT ADHESIVE TO
ALL VERTICAL PAVEMENT EDGES
SEAL EDGES WITH JOINT
SEALANT NYSDOT 705-02

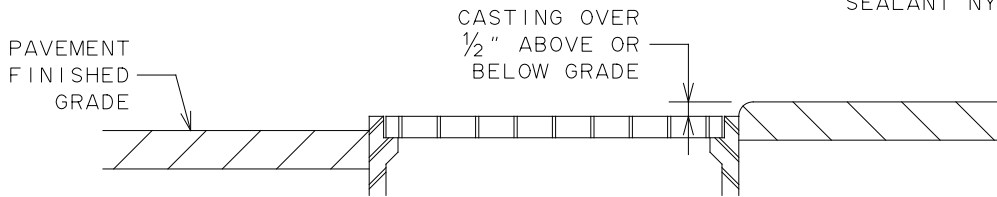

UNACCEPTABLE DEFICIENT CONDITION
(APPURTENANCE TO BE RESET)

VERTICAL DIFFERENCE	CORRECTIVE ACTION
UP TO BUT NOT EXCEEDING 1/4 INCH	NO CORRECTIVE ACTION REQUIRED
OVER 1/4 INCH UP TO 1/2 INCH	DEFICIENT CONDITION - TAKE CORRECTIVE ACTION TO MITIGATE DEFICIENCY - MILL AND RESURFACE SURROUNDING PAVEMENT TO MINIMUM DEPTH 2" - CONTINUE TO MONITOR DEFICIENCY
OVER 1/2 INCH	DEFICIENT CONDITION IS TO BE MITIGATED WITHIN 30 CALENDAR DAYS OF HAVING BEEN IDENTIFIED - RESET EXISTING CASTING PER DETAIL S604-90 UTILITY MANHOLE INSTALLATION - ROUND COLLAR

NOTES:

- CASTINGS ARE TO BE INSTALLED PLANAR, TRUE TO LINE AND GRADE OF SURROUNDING PAVEMENT. COVER/GRATE TO HAVE FULL CONTINUOUS AND UNIFORM BEARING CONTACT WITH CORRESPONDING FRAME.
- TOP OF COVER/GRATE IS TO BE LEVEL WITH TOP OF CORRESPONDING FRAME. IF COVER/GRATE IS BELOW/ ABOVE TOP OF FRAME GREATER THAN 1/4 INCH, IT IS DEFICIENT CONDITION THAT MUST BE MITIGATED WITHIN 30 CALENDAR OF HAVING BEEN IDENTIFIED.
- COVER/GRATE IS TO BE STABLE AND IMMOVABLE WHEN IN PLACE AND WHEN UNDER INFLUENCE OF TRAFFIC OR ANY OTHER TYPE OF LOAD BEARING STRESS.

CITY OF ROCHESTER		
GRADE LEVEL UTILITY APPURTENANCE CONDITION EVALUATION		
ISSUED	11-14-18	NON-STANDARD DWG.NO.S100-1
REVISED	4-1-19	

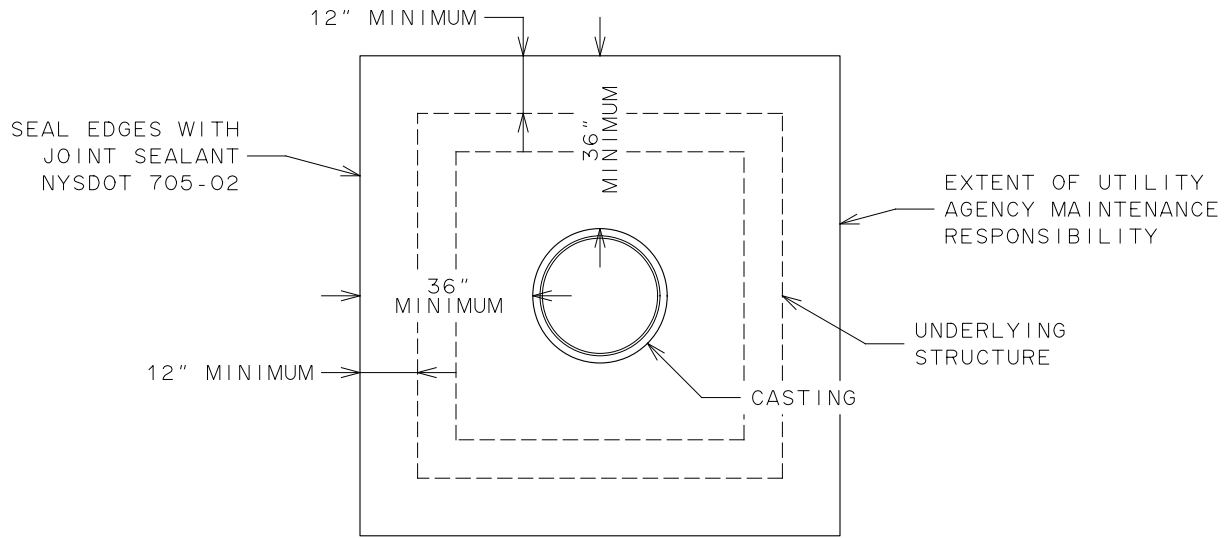

PLAN

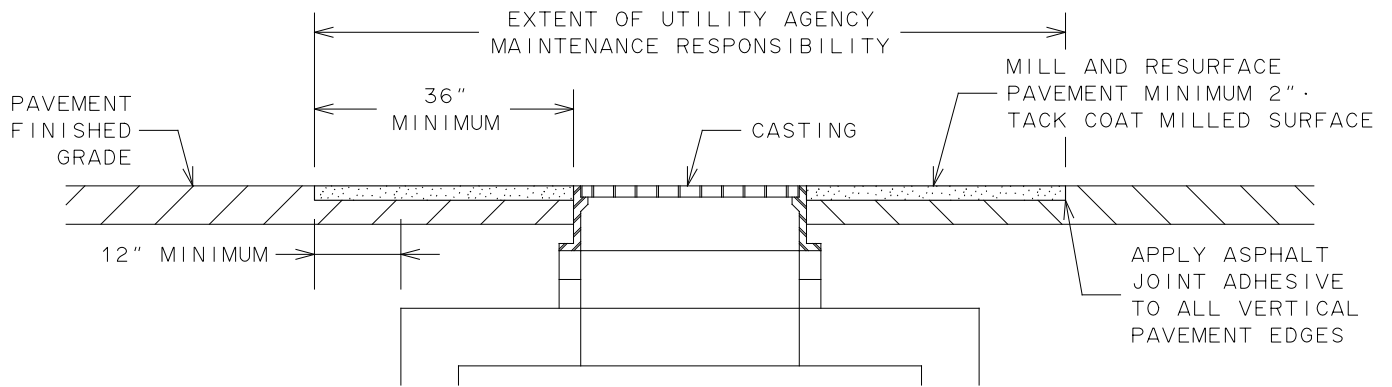

SECTION

CONDITION	CORRECTIVE ACTION
VERY GOOD PCI 100-86	NO ACTION REQUIRED
GOOD PCI 85-71	SEAL ALL CRACKS AND JOINTS
FAIR - POOR PCI 70-26	MILL AND RESURFACE PAVEMENT MINIMUM 2" - APPLY TACK COAT TO MILLED SURFACE AND ASPHALT JOINT ADHESIVE TO ALL VERTICAL PAVEMENT EDGES
SERIOUS - FAILED PCI 25-0	RECONSTRUCT PAVEMENT SECTION IN KIND - APPLY TACK COAT BETWEEN ALL HMA COURSES AND ASPHALT JOINT ADHESIVE TO ALL VERTICAL PAVEMENT EDGES - RESET MANHOLE CASTING PER DETAIL S604-90

NOTES :

- UTILITY AGENCY IS RESPONSIBLE TO MAINTAIN PAVEMENT AREA AROUND UTILITY APPURTENANCE IN GOOD CONDITION 36 INCHES FROM OUTER EDGE OF CASTING, OR 12 INCHES FROM OUTSIDE EDGE OF UNDERLYING STRUCTURE, WHICHEVER IS GREATER.
- PAVEMENT CONDITION INDEX (PCI) IS TO BE RATED IN ACCORDANCE WITH ASTM D6433.
- WHERE CASTINGS ARE IN DEFICIENT CONDITION AND/OR PAVEMENT AREA IS TO BE RECONSTRUCTED, RESET OR REPLACE EXISTING CASTING PER DETAIL S604-90.

CITY OF ROCHESTER		
PAVEMENT CONDITION AT UTILITY APPURTENANCE		
ISSUED	11-14-18	NON-STANDARD DWG.NO.S100-2
REVISED	4-1-19	

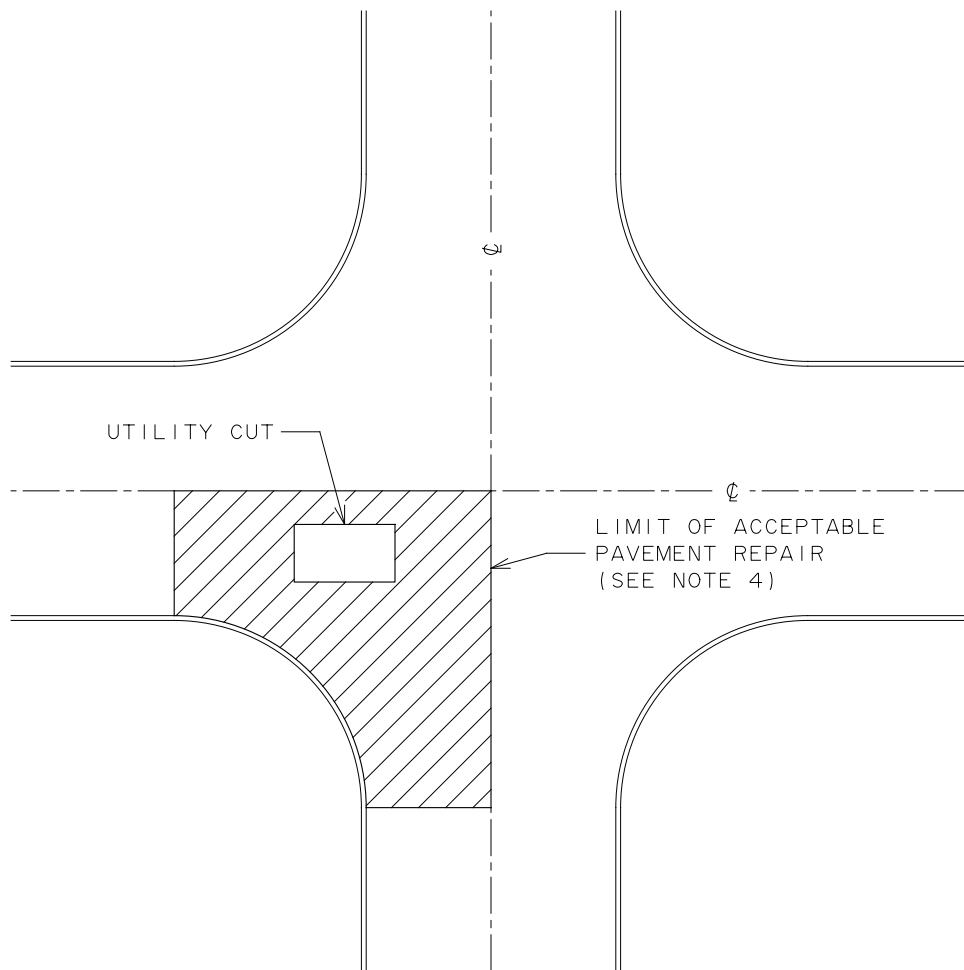

QUARTER INTERSECTION

NOTES:

1. ALL EDGES ARE TO BE SAW CUT FULL DEPTH ALONG NEAT STRAIGHT LINES, PARALLEL AND PERPENDICULAR TO FLOW OF TRAFFIC. PATCHES ARE NOT TO BE IRREGULAR IN SHAPE, OR HAVE ANGLED SIDES.
2. WHERE BACKFILL OF EXCAVATION CANNOT BE PROPERLY COMPLETED WITHIN SINGLE WORKDAY, STEEL PLATE(S) ARE TO BE INSTALLED TO PRESERVE TRAFFIC FLOW.
3. IF STEEL PLATE(S) ARE NOT TO BE UTILIZED, EXCAVATION IS TO BE FINISHED WITH TEMPORARY PAVEMENT SECTION. TEMPORARY PAVEMENT IS TO BE MAINTAINED IN SMOOTH RIDEABLE NON-HAZARDOUS CONDITION UNTIL PERMANENT PAVEMENT RESTORATION CAN BE DONE.
4. OUTER LIMIT OF PAVEMENT REPAIR AREA IS 10' BEYOND OUTER EXTENT OF UTILITY CUT OR TO PC/PT OF RADIUS WHICHEVER IS GREATER.

CITY OF ROCHESTER		
UTILITY CUT PAVEMENT REPAIR LIMIT EXAMPLE I		
ISSUED	4-1-19	NON-STANDARD DWG.NO.SIOI-01
REVISED		

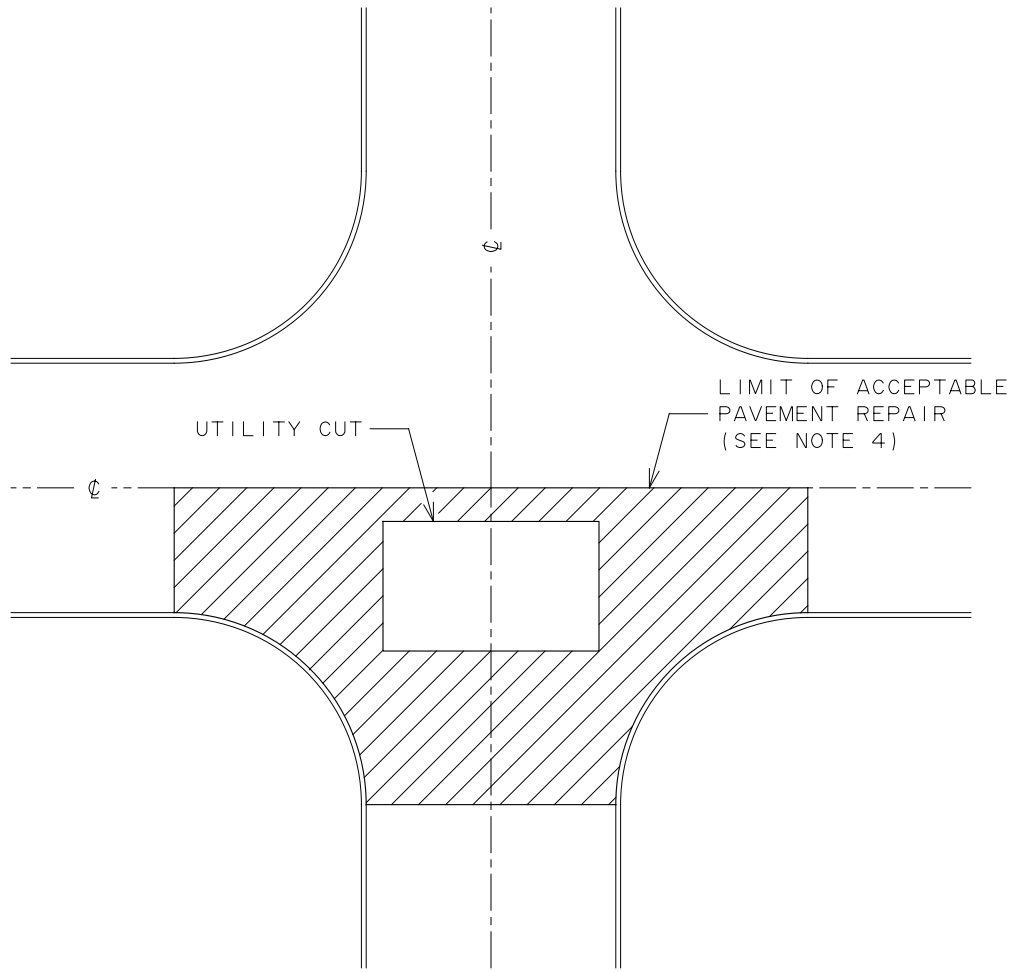

HALF INTERSECTION

NOTES:

1. ALL EDGES ARE TO BE SAW CUT FULL DEPTH ALONG NEAT STRAIGHT LINES, PARALLEL AND PERPENDICULAR TO FLOW OF TRAFFIC. PATCHES ARE NOT TO BE IRREGULAR IN SHAPE, OR HAVE ANGLED SIDES.
2. WHERE BACKFILL OF EXCAVATION CANNOT BE PROPERLY COMPLETED WITHIN SINGLE WORKDAY, STEEL PLATE(S) ARE TO BE INSTALLED TO PRESERVE TRAFFIC FLOW.
3. IF STEEL PLATE(S) ARE NOT TO BE UTILIZED, EXCAVATION IS TO BE FINISHED WITH TEMPORARY PAVEMENT SECTION. TEMPORARY PAVEMENT IS TO BE MAINTAINED IN SMOOTH RIDEABLE NON-HAZARDOUS CONDITION UNTIL PERMANENT PAVEMENT RESTORATION CAN BE DONE.
4. OUTER LIMIT OF PAVEMENT REPAIR AREA IS 10' BEYOND OUTER EXTENT OF UTILITY CUT OR TO PC/PT OF RADIUS WHICHEVER IS GREATER.

CITY OF ROCHESTER		
UTILITY CUT PAVEMENT REPAIR LIMIT EXAMPLE 2		
ISSUED	4-1-19	NON-STANDARD DWG.NO.SIOI-02
REVISED		

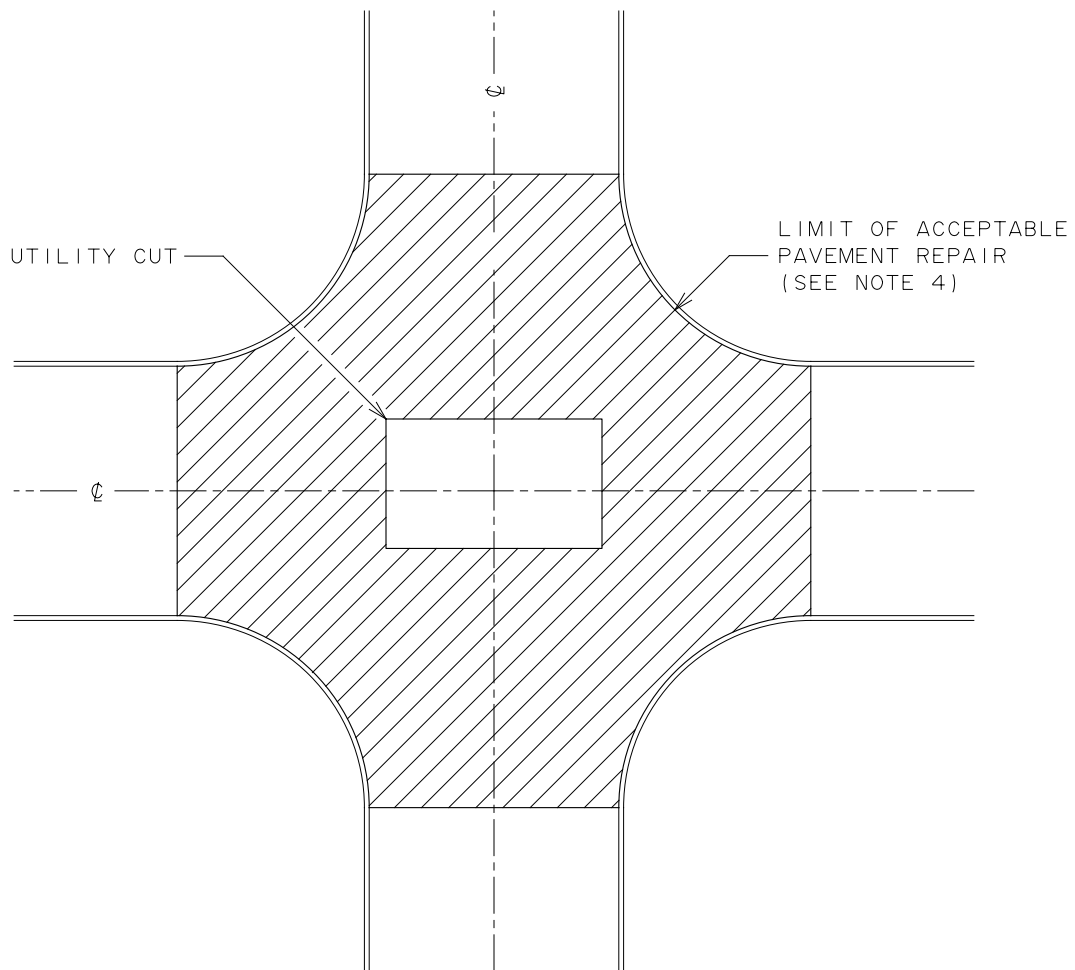

FULL INTERSECTION

NOTES:

1. ALL EDGES ARE TO BE SAW CUT FULL DEPTH ALONG NEAT STRAIGHT LINES, PARALLEL AND PERPENDICULAR TO FLOW OF TRAFFIC. PATCHES ARE NOT TO BE IRREGULAR IN SHAPE, OR HAVE ANGLED SIDES.
2. WHERE BACKFILL OF EXCAVATION CANNOT BE PROPERLY COMPLETED WITHIN SINGLE WORKDAY, STEEL PLATE(S) ARE TO BE INSTALLED TO PRESERVE TRAFFIC FLOW.
3. IF STEEL PLATE(S) ARE NOT TO BE UTILIZED, EXCAVATION IS TO BE FINISHED WITH TEMPORARY PAVEMENT SECTION. TEMPORARY PAVEMENT IS TO BE MAINTAINED IN SMOOTH RIDEABLE NON-HAZARDOUS CONDITION UNTIL PERMANENT PAVEMENT RESTORATION CAN BE DONE.
4. OUTER LIMIT OF PAVEMENT REPAIR AREA IS 10' BEYOND OUTER EXTENT OF UTILITY CUT OR TO PC/PT OF RADIUS WHICHEVER IS GREATER.

CITY OF ROCHESTER		
UTILITY CUT PAVEMENT REPAIR LIMIT EXAMPLE 3		
ISSUED	4-1-19	NON-STANDARD
REVISED		DWG.NO.SIOI-03

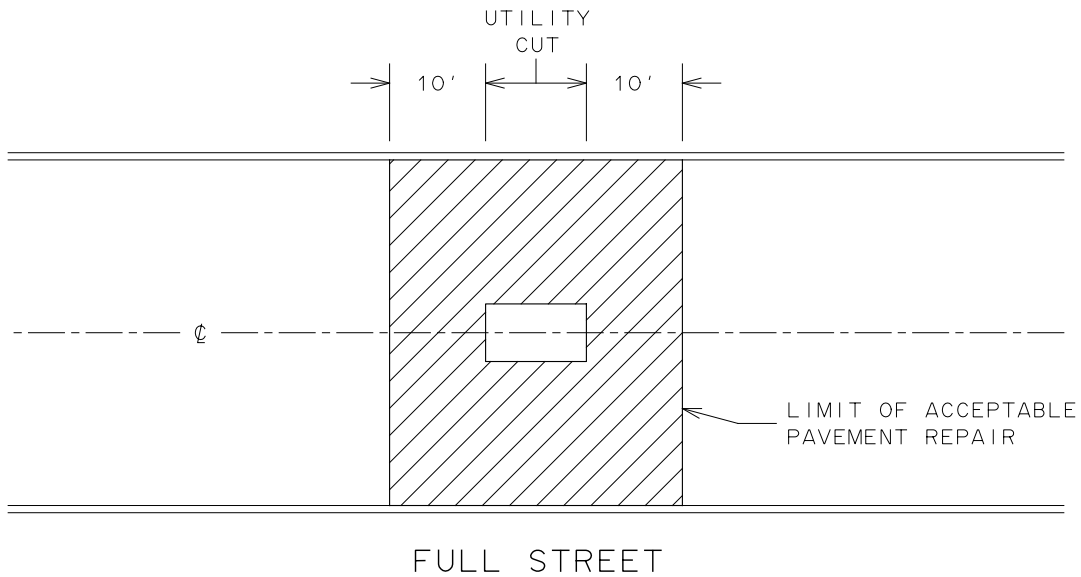
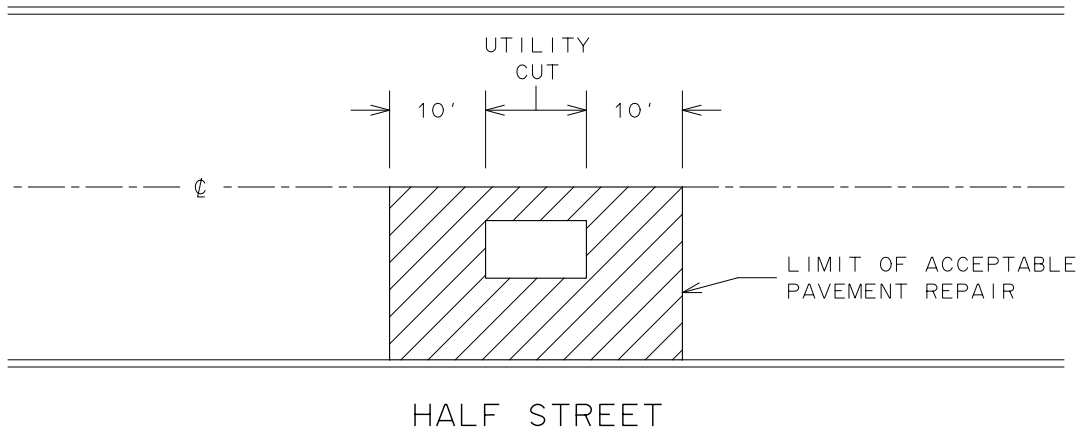

NOTES :

1. ALL EDGES ARE TO BE SAW CUT FULL DEPTH ALONG NEAT STRAIGHT LINES, PARALLEL AND PERPENDICULAR TO FLOW OF TRAFFIC. PATCHES ARE NOT TO BE IRREGULAR IN SHAPE, OR HAVE ANGLED SIDES.
2. WHERE BACKFILL OF EXCAVATION CANNOT BE PROPERLY COMPLETED WITHIN SINGLE WORKDAY, STEEL PLATE(S) ARE TO BE INSTALLED TO PRESERVE TRAFFIC FLOW.
3. IF STEEL PLATE(S) ARE NOT TO BE UTILIZED, EXCAVATION IS TO BE FINISHED WITH TEMPORARY PAVEMENT SECTION. TEMPORARY PAVEMENT IS TO BE MAINTAINED IN SMOOTH RIDEABLE NON-HAZARDOUS CONDITION UNTIL PERMANENT PAVEMENT RESTORATION CAN BE DONE.

CITY OF ROCHESTER		
UTILITY CUT PAVEMENT REPAIR LIMIT EXAMPLE 4		
ISSUED	4-1-19	NON-STANDARD DWG.NO.SIOI-04
REVISED		

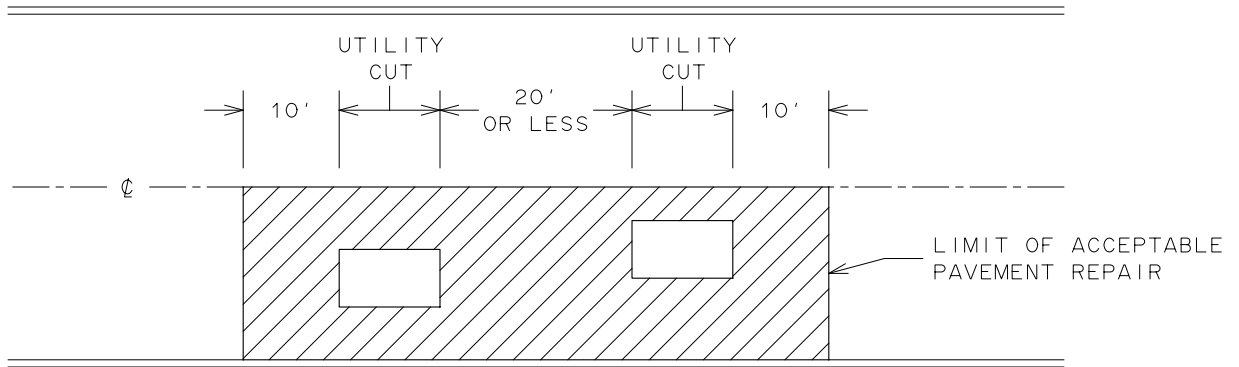

HALF STREET

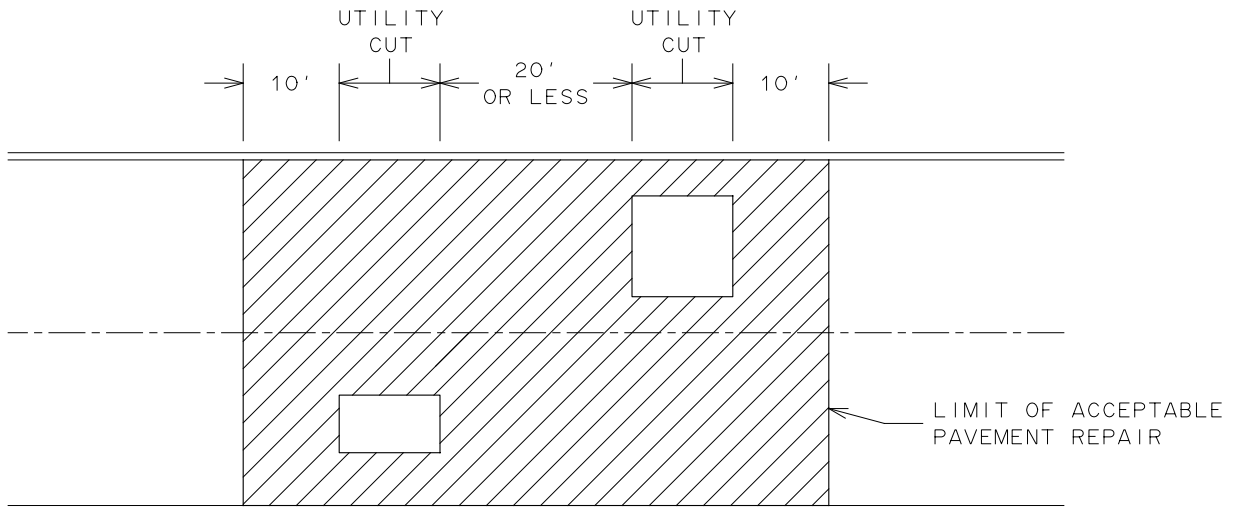

FULL STREET

NOTES :

1. ALL EDGES ARE TO BE SAW CUT FULL DEPTH ALONG NEAT STRAIGHT LINES, PARALLEL AND PERPENDICULAR TO FLOW OF TRAFFIC. PATCHES ARE NOT TO BE IRREGULAR IN SHAPE, OR HAVE ANGLED SIDES.
2. WHERE BACKFILL OF EXCAVATION CANNOT BE PROPERLY COMPLETED WITHIN SINGLE WORKDAY, STEEL PLATE(S) ARE TO BE INSTALLED TO PRESERVE TRAFFIC FLOW.
3. IF STEEL PLATE(S) ARE NOT TO BE UTILIZED, EXCAVATION IS TO BE FINISHED WITH TEMPORARY PAVEMENT SECTION. TEMPORARY PAVEMENT IS TO BE MAINTAINED IN SMOOTH RIDEABLE NON-HAZARDOUS CONDITION UNTIL PERMANENT PAVEMENT RESTORATION CAN BE DONE.

CITY OF ROCHESTER		
UTILITY CUT PAVEMENT REPAIR LIMIT EXAMPLE 5		
ISSUED	4-1-19	NON-STANDARD
REVISED		DWG.NO.SIOI-05

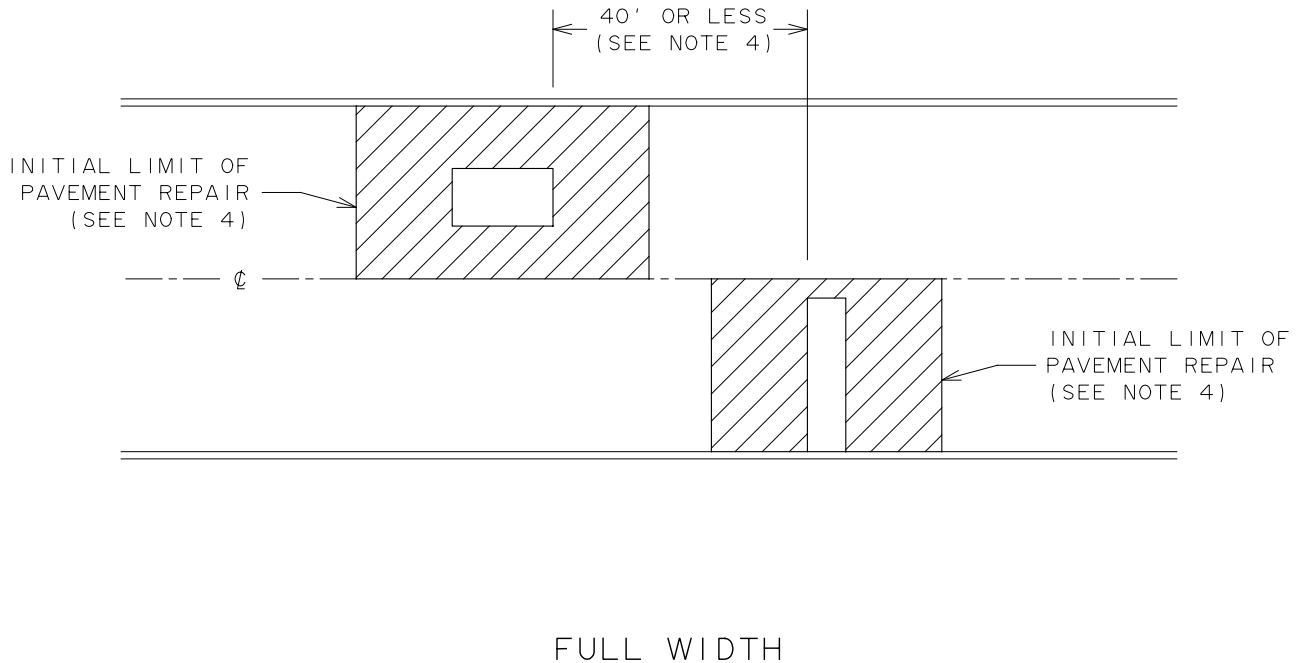
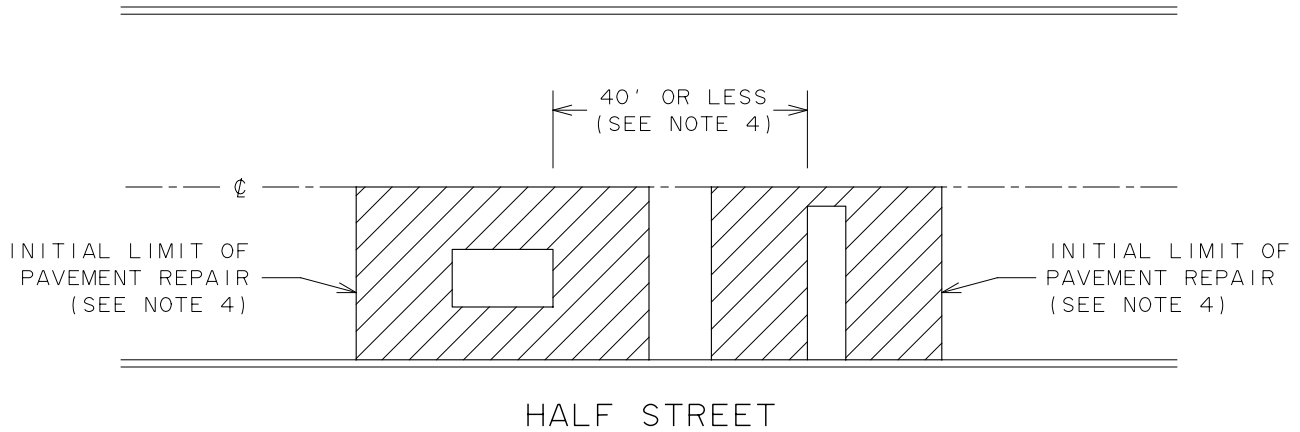

NOTES:

1. ALL EDGES ARE TO BE SAW CUT FULL DEPTH ALONG NEAT STRAIGHT LINES, PARALLEL AND PERPENDICULAR TO FLOW OF TRAFFIC. PATCHES ARE NOT TO BE IRREGULAR IN SHAPE, OR HAVE ANGLED SIDES.
2. WHERE BACKFILL OF EXCAVATION CANNOT BE PROPERLY COMPLETED WITHIN SINGLE WORKDAY, STEEL PLATE(S) ARE TO BE INSTALLED TO PRESERVE TRAFFIC FLOW.
3. IF STEEL PLATE(S) ARE NOT TO BE UTILIZED, EXCAVATION IS TO BE FINISHED WITH TEMPORARY PAVEMENT SECTION. TEMPORARY PAVEMENT IS TO BE MAINTAINED IN SMOOTH RIDEABLE NON-HAZARDOUS CONDITION UNTIL PERMANENT PAVEMENT RESTORATION CAN BE DONE.
4. WHERE DISTANCE BETWEEN OUTER EXTENT OF UTILITY CUTS IS 40' OR LESS, SPECIAL REVIEW IS REQUIRED BY PERMIT OFFICE TO DETERMINE OVERALL LIMITS OF PAVEMENT RESTORATION AREA.

CITY OF ROCHESTER		
UTILITY CUT PAVEMENT REPAIR LIMIT EXAMPLE 6		
ISSUED	4-1-19	NON-STANDARD
REVISED		DWG.NO.SIOI-06

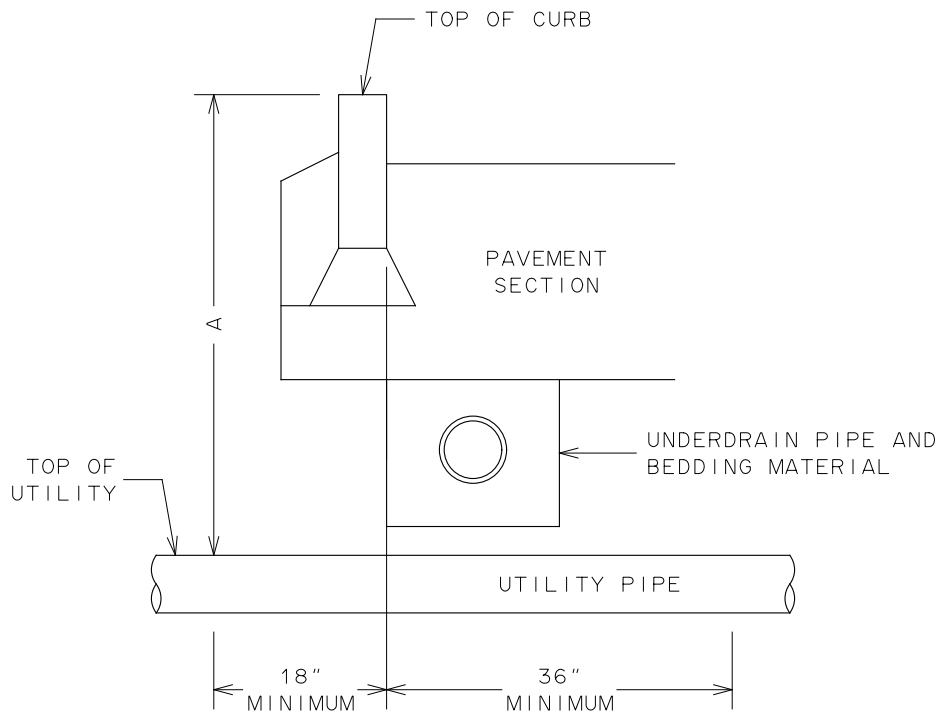

PAVEMENT SECTION	"A" INCHES MINIMUM DEPTH OF UTILITY INSTALLATION FROM TOP OF CURB TO TOP OF UTILITY
LIGHT-DUTY ASPHALT	41"
MEDIUM-DUTY ASPHALT	44"
MODIFIED-DUTY ASPHALT	46"
HEAVY-DUTY ASPHALT	48"
CONCRETE AND SPECIALTY TYPE	45" MINIMUM

NOTE :

UTILITIES INSTALLED UNDER CURB MUST BE DEEP ENOUGH TO PASS UNDER UNDERDRAIN PIPE AND BEDDING MATERIAL.

CITY OF ROCHESTER		
UTILITY INSTALLATION UNDER CURB		
ISSUED	4-1-19	NON-STANDARD DWG.NO.SIO2-01
REVISED		

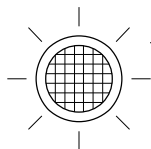

TYPE B FLASHING HIGH INTENSITY WARNING LIGHT

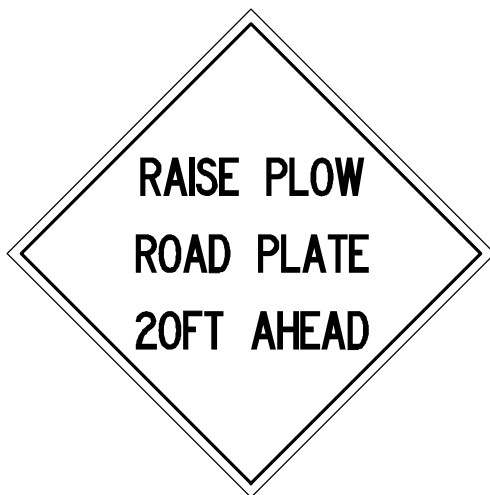

SIGN BOARD :

- SIZE 36" x 36"
- ORANGE BACKGROUND WITH INNER BLACK LINE
- CLEAR MARGIN $\frac{5}{8}$ " ALL AROUND
- INNER BLACK LINE $\frac{7}{8}$ " WIDE

LETTERS :

- BLACK, 4" TYPE C WITH 4" LINE SPACING

NOTES :

1. SIGN IS TO BE PLACED MINIMUM 20 FEET IN ADVANCE OF ROAD PLATE AND WITHIN 2 FEET OF PAVEMENT EDGE.
2. BOTTOM OF SIGN IS TO BE MINIMUM OF 5 FEET ABOVE GROUND.
3. SIGN IS TO BE LOCATED SUCH AS TO ACHIEVE MAXIMUM VISIBILITY AND WITHOUT INTERFERRING WITH SIGHT DISTANCE FOR PEDESTRIANS, BICYCLISTS AND MOTORISTS.

CITY OF ROCHESTER		
RAISE PLOW ROAD PLATE AHEAD WARNING SIGN		
ISSUED	4-25-96	NON-STANDARD DWG.NO.S999-1
REVISED	1-1-17	

UTILITY	SIZE	DEPTH GUIDELINE	LOCATION GUIDELINE	DESIRED LATERAL SEPARATION FROM								
				SEWERS	WATERMAIN	GAS MAIN	ELEC. COND.	TEL. COND.	CTV COND.	STREET LT. COND.	TRAF. SIG.	
SEWER	8" to more than 60" diam.	96"	Center of ROW	—	10'	3'	3'	3'	3'	3'	3'	3'
WATER MAIN	8" - 12" diam. 24" - 36" (trans.)	54"	4' to 5' off curb	10'	—	3'	3'	3'	3'	3'	3'	3'
GAS MAIN	2" - 12" diam. 16" - 24" (trans.)	36"	Curb to ROW line	3'	3'	—	3'	3'	3'	3'	3'	3'
ELEC. CONDUIT	5" diam.	30" - 36" (bc) 36" - 48" (pvt)	Pavement area	3'	3'	3'	—	18"	18"	18"	18"	18"
ELEC. MH	6' x 11' x 6' deep	Roof varies based on type of pvt	Pavement area	2'	2'	2'	—	18"	18"	18"	18"	18"
TEL. CONDUIT	4" diam.	30" - 36" (bc) 36" - 48" (pvt)	Pavement area	3'	3'	3'	18"	—	18"	18"	18"	18"
TEL. MANHOLE	5' x 10' x 6' deep	Roof varies based on type of pvt	Pavement area	2'	2'	2'	18"	—	18"	18"	18"	18"
CABLE TV COND.	3" - 4" diam.	30" (bc) 36" (pvt)	Curb to ROW line	3'	3'	3'	18"	18"	—	18"	18"	18"
STREET LT. COND.	2" - 3" diam.	24" (bc) 36" (pvt)	Curb to ROW line	3'	3'	3'	18"	18"	18"	—	18"	18"
TRAF. SIG. COND.	3" - 4" diam.	24" (bc) 24" (pvt)	Curb to ROW line	3'	3'	3'	18"	18"	18"	18"	—	18"
ROAD UNDERD'N	6" diam.	22" (med pvt) 27" (hvy pvt)	6" off curb	2'	2'	2'	2'	2'	2'	2'	2'	2'

UTILITY COORDINATING COMMITTEE MEMBERS:

- City of Rochester
- Eastman Kodak Company
- Greater Rochester Cablevision
- Monroe County Traffic Bureau
- Monroe County Water Authority
- Ogden Telephone
- Rochester Gas & Electric
- Rochester Telephone
- Town of Greece
- Town of Henrietta
- Village of Fairport
- Village of Spencerport



**CITY OF ROCHESTER
UTILITY LOCATION GUIDELINES**