

REHABILITATION

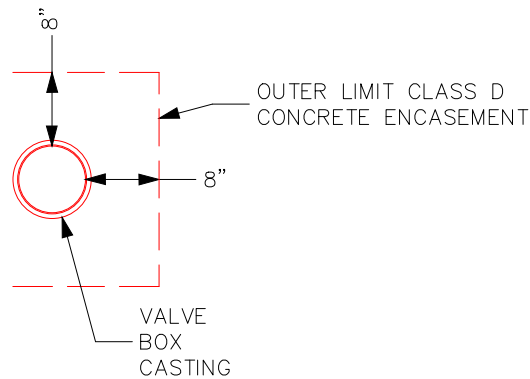

RECONSTRUCTION

PLANS

← LIMITS AS SPECIFIED IN CONTRACT DOCUMENTS OR S101 SERIES DETAILS →

← PAVEMENT SECTION AND LIMITS AS SPECIFIED IN CONTRACT DOCUMENTS →

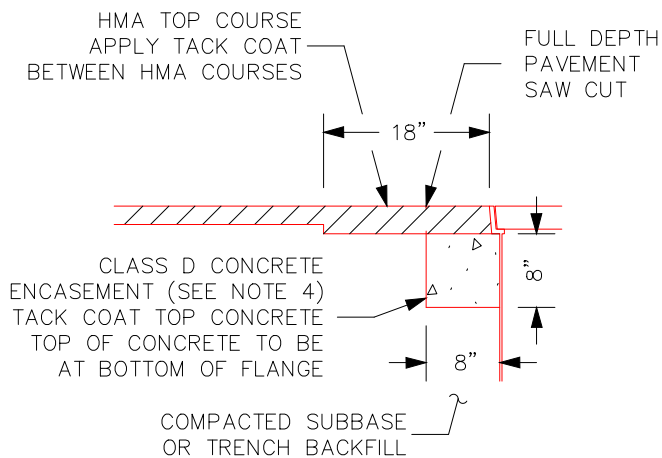

REHABILITATION

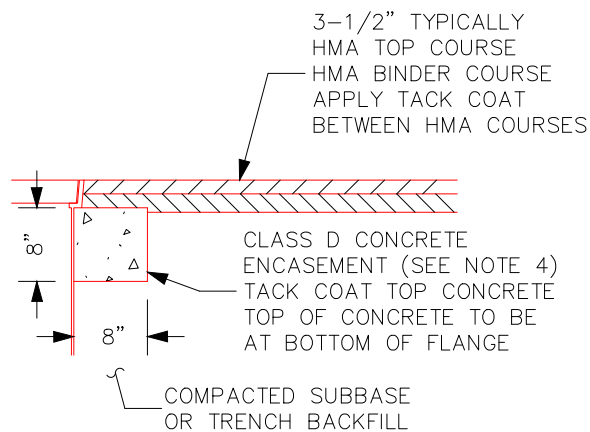

RECONSTRUCTION

SECTIONS

NOTES:

1. CASTING IS TO BE IN SAME HORIZONTAL PLANE AS SURROUNDING SURFACE, TRUE TO LINE AND GRADE, WITH COVER HAVING FULL CONTINUOUS AND UNIFORM BEARING CONTACT WITH FRAME.
2. TOP OF COVER IS TO BE LEVEL WITH TOP OF FRAME, STABLE AND IMMOVABLE WHEN IN PLACE AND WHEN UNDER INFLUENCE OF TRAFFIC OR ANY OTHER TYPE OF LOAD BEARING STRESS.
3. IF CASTING IS BELOW/ABOVE TOP OF SURROUNDING SURFACE GREATER THAN INCH, IT IS DEFICIENT CONDITION THAT MUST BE MITIGATED PER DETAIL S100-01 OF "RULES AND REGULATIONS FOR WORK IN THE RIGHT-OF-WAY".
4. HIGH EARLY STRENGTH CONCRETE IS TO BE USED FOR PLACEMENTS REQUIRED TO SATISFY OPEN TO TRAFFIC TIME REQUIREMENTS.

**THIS DETAIL MAY ONLY BE USED IN CONJUNCTION WITH PAVEMENT REHABILITATION OR RECONSTRUCTION**

CITY OF ROCHESTER	
ASPHALT PAVEMENT RESTORATION FOR VALVE BOX WITHIN ROADWAY	
ISSUED	6-24-19
REVISED	8-29-19
NON-STANDARD DWG.NO.S909-03	