

PLAN

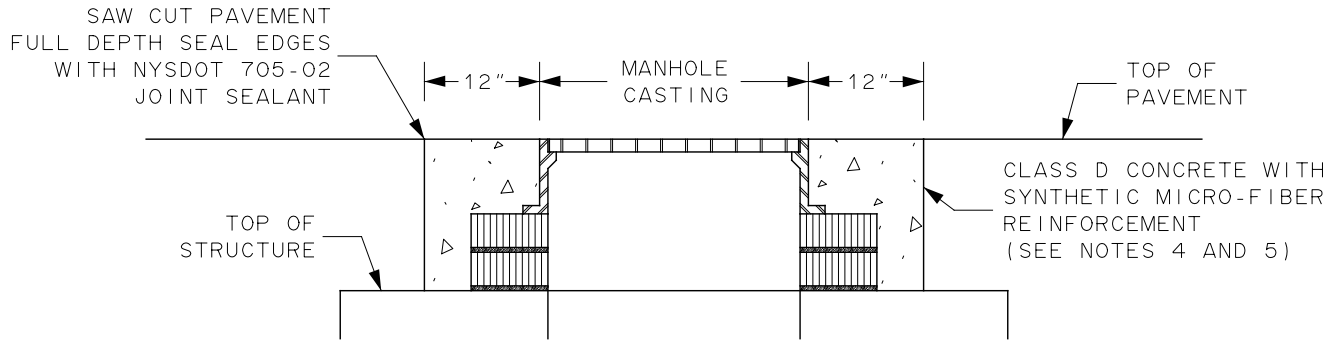

SECTION

NOTES :

1. CASTING AND TOP OF CONCRETE ARE TO BE IN SAME HORIZONTAL PLANE AS SURROUNDING SURFACE, TRUE TO LINE AND GRADE, WITH COVER HAVING FULL CONTINUOUS AND UNIFORM BEARING CONTACT WITH FRAME.
2. TOP OF COVER IS TO BE LEVEL WITH TOP OF FRAME, STABLE AND IMMOVABLE WHEN IN PLACE AND WHEN UNDER INFLUENCE OF TRAFFIC OR ANY OTHER TYPE OF LOAD BEARING STRESS.
3. IF CASTING IS BELOW/ABOVE TOP OF SURROUNDING SURFACE GREATER THAN 1/4 INCH, IT IS DEFICIENT CONDITION THAT MUST BE MITIGATED PER DETAIL S100-01 OF "RULES AND REGULATIONS FOR WORK IN THE RIGHT-OF-WAY".
4. HIGH EARLY STRENGTH CONCRETE IS TO BE USED FOR PLACEMENTS REQUIRED TO SATISFY OPEN TO TRAFFIC TIME REQUIREMENTS.
5. DEPTH OF CONCRETE IS TO BE MINIMUM 12 INCHES. ACTUAL DEPTH TO BE EITHER TO EXISTING CONSTRUCTION JOINT OR SOUND CONCRETE/BRICK.
6. OUTER EDGE OF CONCRETE IS TO BE PARALLEL WITH PAVEMENT EDGE.

NOTE :

REFER TO APPROPRIATE UTILITY/ AGENCY CONSTRUCTION STANDARDS FOR INSTALLATION/ADJUSTMENT OF MANHOLE FRAME AND COVER

7. IF PAVEMENT IS CUT AND CORE LEFT IN PLACE FOR REMOVAL AT LATER TIME VOID IS TO BE FILLED-IN WITH ASPHALT COLD PATCH OR MILLINGS. VOID IS NOT TO BE LEFT OPEN OVERNIGHT.

THIS DETAIL MAY ONLY BE USED AT SOLE DISCRETION OF CITY ENGINEER

CITY OF ROCHESTER		
ALTERNATE SQUARE CONCRETE COLLAR FOR MANHOLE WITHIN ROADWAY		
ISSUED	11-14-18	NON-STANDARD DWG.NO.S604-91
REVISED	11-27-19	