

PLAN

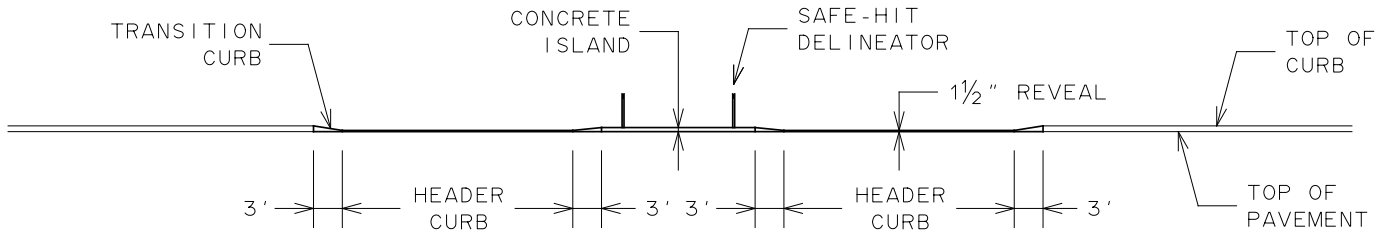

VIEW

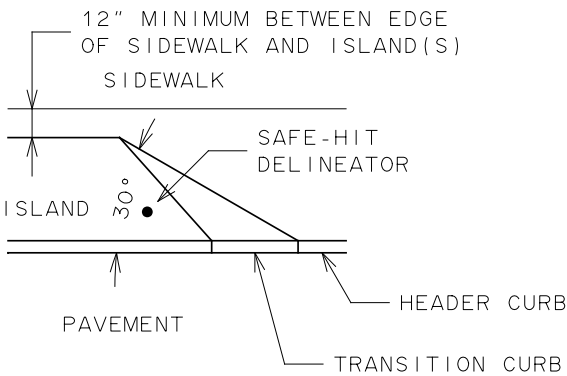

DETAIL

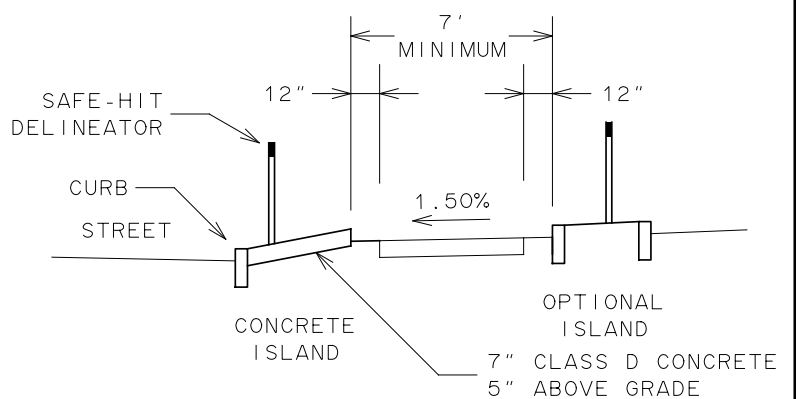

SECTION

NOTES:

1. TYPICAL LAYOUT FOR RIGHT-IN/RIGHT-OUT DRIVEWAY OPENING. ACTUAL LAYOUT OF ISLAND AND OVERALL DIMENSIONS WILL DEPEND ON WIDTH OF CURB PARK AREA.
2. NOMINAL HEADER CURB LENGTH IS BETWEEN 12 AND 16 FEET. FINAL DESIGN AND LAYOUT OF DRIVEWAY OPENING WILL BE AS APPROVED BY CITY.
3. FULL DEPTH 1/2 INCH WIDE EXPANSION JOINT AROUND OUTER LIMITS OF DRIVEWAY APRON WHERE ABUTS OTHER PAVED SURFACES.
4. MAXIMUM DESIRABLE DRIVEWAY APRON SLOPE, 8% FOR RESIDENTIAL DRIVEWAY, 6% FOR COMMERCIAL DRIVEWAY.

CITY OF ROCHESTER		
RIGHT-IN/RIGHT-OUT DRIVEWAY APRON WITH CONCRETE ISLAND		
ISSUED	8-16-13	NON-STANDARD DWG.NO.S608-37
REVISED	5-15-20	