

PAVEMENT MILLING

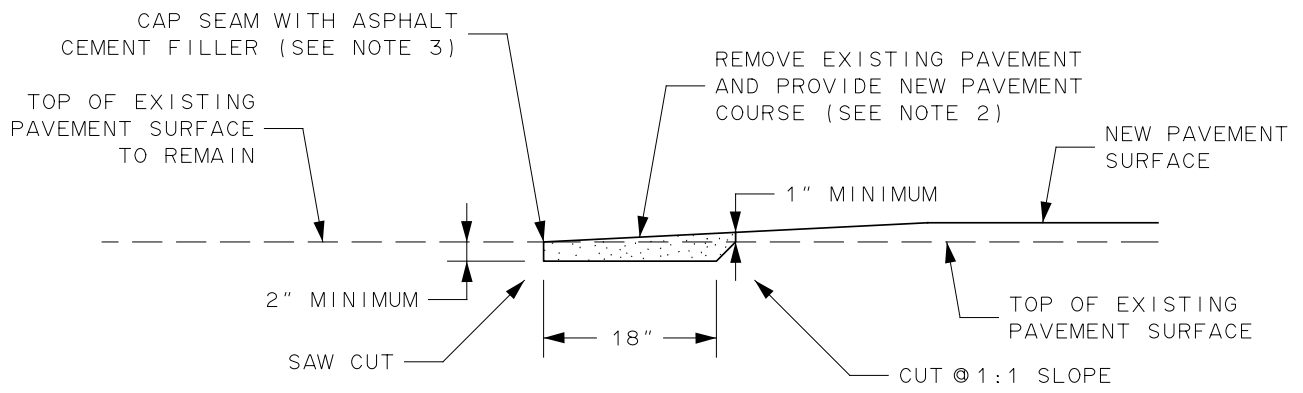

PAVEMENT RESURFACING

NOTES :

1. PAVEMENT KEY WILL BE REQUIRED ON MAIN LINE OF NEW AND EXISTING PAVEMENTS, AT MAJOR INTERSECTIONS, AT OTHER LOCATIONS SHOWN ON PLANS OR AOBPM TO PROVIDE SMOOTH RIDING PAVEMENT TRANSITION.
2. PAVEMENT KEYS ARE TO BE CONSTRUCTED SAME DAY AS NEW ASPHALT TOP COURSE IS PLACED, AND ARE NOT TO BE LEFT OPEN OVERNIGHT.
3. ALL SEAMS BETWEEN EXISTING AND NEW PAVEMENT ARE TO BE SEALED WITH ASPHALT CEMENT 702-0700 IN ACCORDANCE WITH NYS DOT SECTION 702 BITUMINOUS MATERIALS.

CITY OF ROCHESTER		
PAVEMENT KEY		
ISSUED	1-13-06	NON-STANDARD DWG.NO.S406-1
REVISED	7-2-21	